

REV.	ECN NO OR DESCRIPTION	REVISED	DATE
A	PRODUCT RELEASE	Cheney	2017.06.07

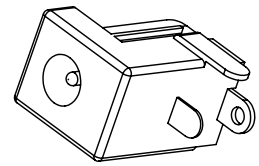

- SPECIFICATIONS:**
- ELECTRICAL CHARACTERISTICS:**
 - RATING: 20 VDC 4A
 - DIELECTRIC WITHSTANDING VOLTAGE: 500 VAC FOR ONE MINUTE.
 - INSULATION RESISTANCE: 100MΩ MIN. MEASURED BY 500V DC.
 - CONTACT RESISTANCE: 30mΩ MAX. (INITIAL)
 - MECHANICAL CHARACTERISTICS:**
 - INSERTION FORCE : 0.2~2.5 KGF
 - WITHDRAWAL FORCE : 0.2~3.0 KGF
 - LIFE TEST: 5,000 CYCLES MIN.
 - OTHER GENERAL SPEC. TO REFER "2DC-0005 SERIES_SPEC".
 - TO CONFORM TO SINGATRON HAZARDOUS SUBSTANCE FREE SPEC.
 - HALOGEN FREE PRODUCT IDENTIFICATION MARK ON PRODUCT:
 - HALOGEN FREE PRODUCT IDENTIFICATION LABEL ON PACKAGING:
 - FOR REFLOW SOLDERING LEAD FREE PROCESS.
 - PACKAGING: BAG
 - PRINTED DATE CODE "YYMMDD" ON TOP OF CONNECTOR.

DD: DAY
MM: MONTH
YY: YEAR

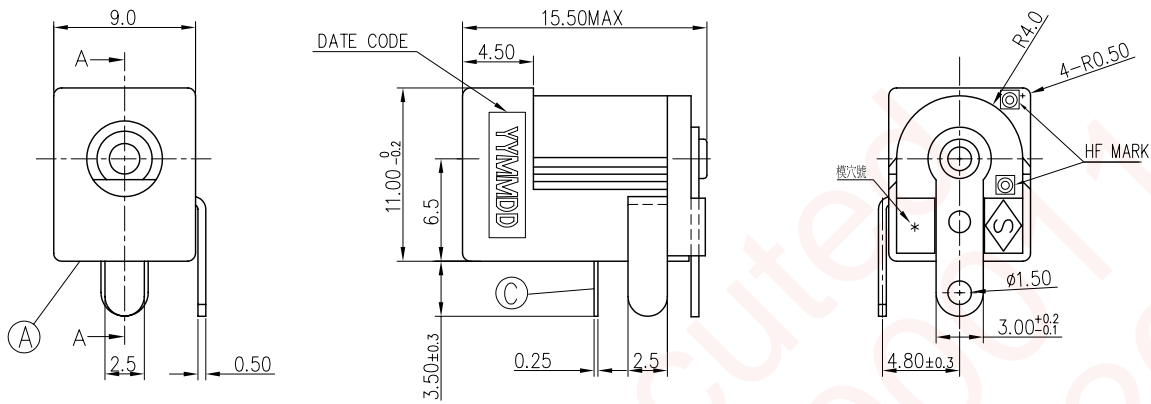
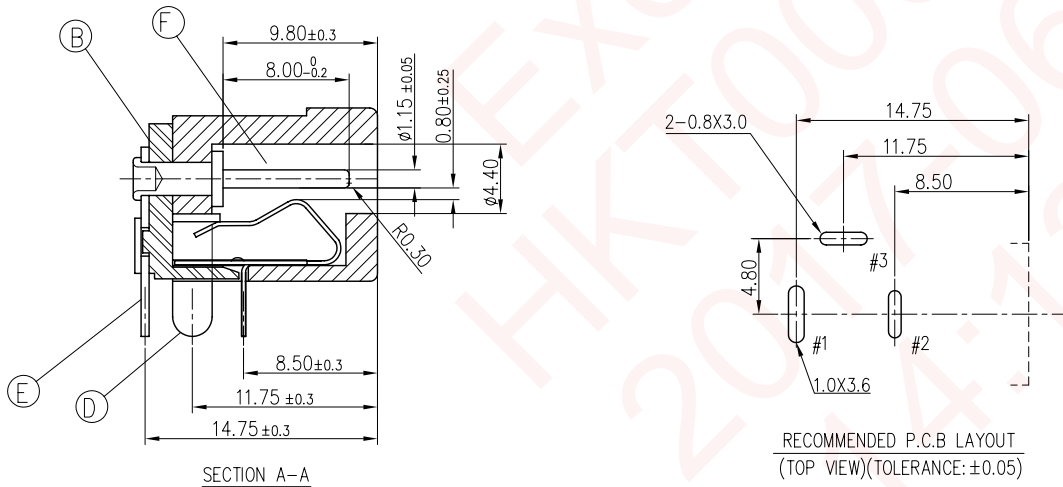

RECOMMENDED P.C.B LAYOUT
(TOP VIEW)(TOLERANCE: ±0.05)

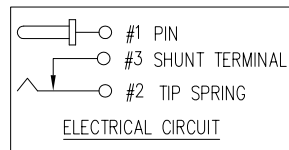
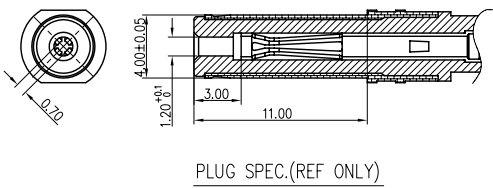

NO	DESCRIPTION	QTY	MATERIAL	PLATING & COLOR
F	PIN	1	COPPER ALLOY	NICKEL PLATING
E	TERMINAL	1	COPPER ALLOY,0.5T	SILVER PLATING
D	SHUNT TERMINAL	1	COPPER ALLOY,0.5T	SILVER PLATING
C	TIP SPRING	1	COPPER ALLOY,0.25T	SILVER PLATING
B	COVER	1	PBT+15%GF,UL94V-0	WHITE
A	BODY	1	PBT+15%GF,UL94V-0	WHITE

UNLESS OTHERWISE SPECIFIED TOLERANCES		Singatron Enterprise Co., Ltd. 信音企業股份有限公司	
DECIMALS: X : ±0.5 X.X : ±0.3 X.XX : ±0.2		TITLE: DC POWER JACK PART NO. 2DC-0005-G20F SCALE 1:1 UNIT: mm SIZE: A3 SHEET: 10F1 REV: A	
ANGLES: X : ±2' X.X : ±1'		CUSTOMER COPY	

副理

研發部(CS)

周吉洲

2017/06/22
09:06:46