

REV.	ECN NO. OR DESCRIPTION	REVISED	DATE
A	PRODUCT RELEASE	HENG	2017.12.21

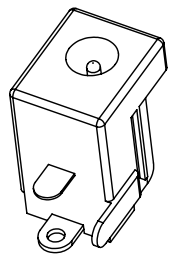

- SPECIFICATIONS:
- ELECTRICAL CHARACTERISTICS:
 - 1-1. RATING: 20V DC, 4A
 - 1-2. DIELECTRIC WITHSTANDING VOLTAGE: 500V AC FOR ONE MINUTE.
 - 1-3. INSULATION RESISTANCE: 100MΩ MIN. MEASURED BY 500V DC.
 - 1-4. CONTACT RESISTANCE: 30mΩ MAX. (INITIAL)
 - MECHANICAL CHARACTERISTICS:
 - 2-1. INSERTION FORCE: 0.2~2.5 KGF
 - 2-2. WITHDRAWAL FORCE: 0.2~3.0 KGF
 - 2-3. LIFE TEST: 5,000 CYCLES MIN.
 - OTHER GENERAL SPEC. TO REFER "2DC-0005 SERIES_SPEC".
 - TO CONFORM TO SINGATRON HAZARDOUS SUBSTANCE FREE SPEC.
 - HALOGEN FREE PRODUCT IDENTIFICATION MARK ON PRODUCT:
 - HALOGEN FREE PRODUCT IDENTIFICATION LABEL ON PACKAGING:
 - FOR REFLOW SOLDERING LEAD FREE PROCESS.
 - PACKAGING: BAG
 - PRINTED DATE CODE "YMMD" ON TOP OF CONNECTOR.

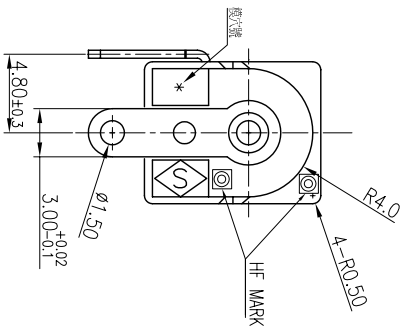
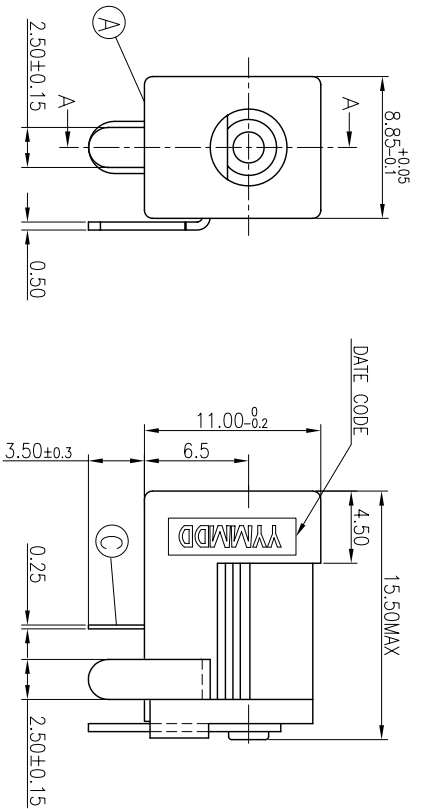
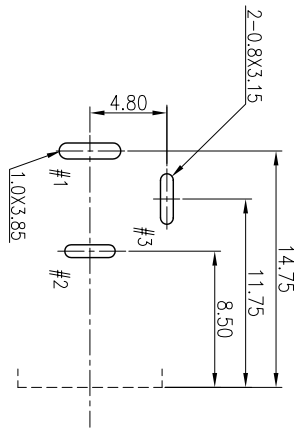
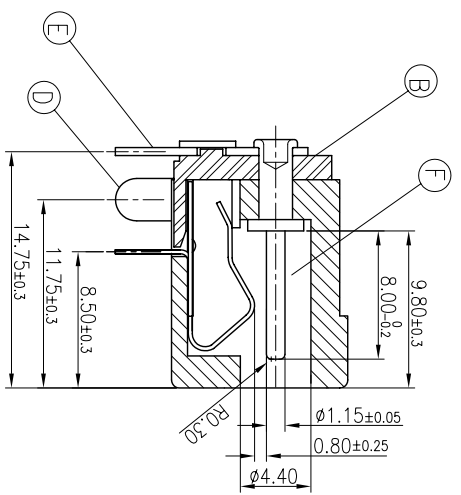
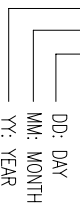

RECOMMENDED P.C.B. LAYOUT
(TOP VIEW) (TOLERANCE: ±0.05)

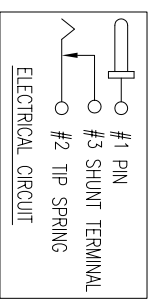
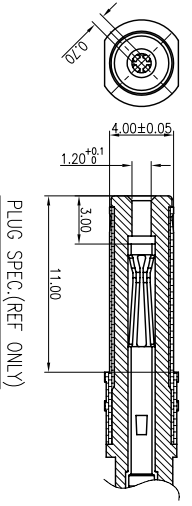

NO	DESCRIPTION	MATERIAL	PLATING & COLOR
F	PIN	1 COPPER ALLOY	NICKEL PLATING
E	TERMINAL	1 COPPER ALLOY 0.5T	SILVER PLATING
D	SHUNT TERMINAL	1 COPPER ALLOY 0.5T	SILVER PLATING
C	TIP SPRING	1 COPPER ALLOY 0.25T	SILVER PLATING
B	COVER	1 PBT+15%GF, JI.94V-0	WHITE
A	BODY	1 PBT+15%GF, JI.94V-0	WHITE

Singaton Enterprise Co., Ltd.
信亨企業股份有限公司

UNLESS OTHERWISE SPECIFIED TOLERANCES		DC POWER JACK	
DECIMALS:	ANGLES:	TITLE	UNIT:
X ±0.5	X ±2°	DWN	mm
XX ±0.3	XX ±1°	CHKD	mm
XXX ±0.2		APVD	mm

CUSTOMER COPY