

REV.	ECN NO OR DESCRIPTION	REVISED	DATE
A	PRODUCT RELEASE	BILL	2010.09.14

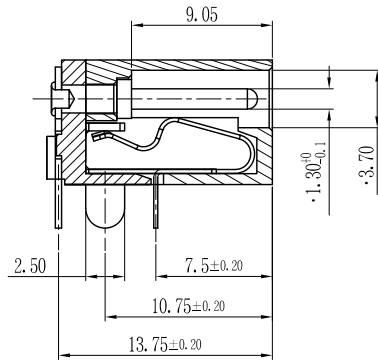

SECTION A-A

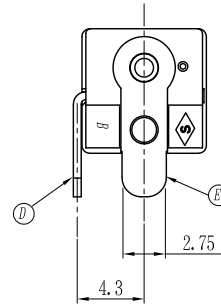
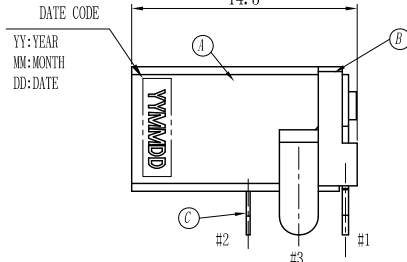
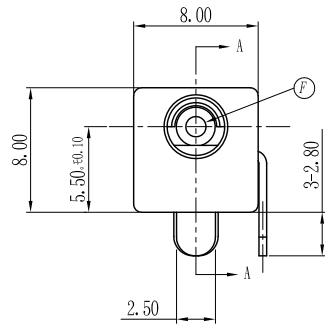
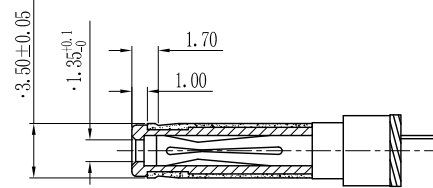

MATE PLUG

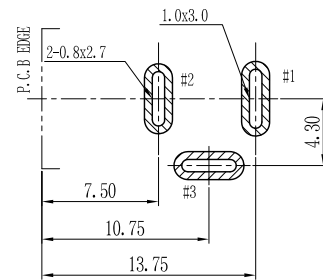
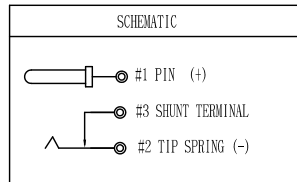

RECOMMENDED PCB LAYOUT

(TOP VIEW) (TOL. : ±0.05)

SPECIFICATIONS:

- ELECTRICAL CHARACTERISTICS:
 - RATING: 16V 3A
 - CONTACT RESISTANCE: 30m MAX. (INITIAL)
 - DIELECTRIC WITHSTANDING VOLTAGE: 500V AC FOR ONE MINUTE.
 - INSULATION RESISTANCE: 100M MIN. MEASURED BY 500 VDC
- MECHANICAL CHARACTERISTICS:
 - INSERTION FORCE : 0.5~2.5 KGF.
 - WITHDRAWAL FORCE : 0.5~3.0KGF.
- LIFE TEST: 5,000 CYCLES MIN.
- OTHER GENERAL SPEC. TO REFER "2DC-0005 SPEC".
- TO CONFORM TO SINGATRON HAZARDOUS SUBSTANCE FREE SPEC.
- HALOGEN FREE PRODUCT IDENTIFICATION MARK ON JACK:
- HALOGEN FREE PRODUCT IDENTIFICATION LABEL ON PACKAGING:
- FOR REFLOW SOLDERING LEAD-FREE PROCESS.
- PACKAGING: BAG.



F	PIN	1	COPPER ALLOY	Ni PLATING
E	TERMINAL	1	COPPER ALLOY 0.40T	Ag PLATING
D	SHUNT TERMINAL	1	COPPER ALLOY 0.50T	Ag PLATING
C	TIP SPRING	1	COPPER ALLOY 0.25T	Ag PLATING
B	COVER	1	HIGH TEMP. THERMOPLASTIC	BLACK COLOR
A	BODY	1	UL 94V-0	BLACK COLOR
NO	DESCRIPTION	QTY	MATERIAL	PLATING & COLOR
UNLESS OTHERWISE SPECIFIED TOLERANCES			Singatron Enterprise Co., Ltd. 信音企業股份有限公司	
DECIMALS:		ANGLES:	TITLE: 1.3 DC POWER JACK	
X	: ±0.5	X	: ±2°	DWN Bill 10.09.16 PART NO. 2DC-0005-H20
X.X	: ±0.3	X.X	: ±1°	CHKD Winkun 10.09.16 SCALE 3 : 1 UNIT: mm
X.XX	: ±0.2			APVD Lino 10.09.16 SIZE: A3 SHEET: 10F1 REV: A
CUSTOMER COPY				