

REV.	ECN NO OR DESCRIPTION	REVISED	DATE
A	PRODUCT RELEASE	BILL	2010.09.24
B	ECN NO:C110003 MODIFY DIM	LONGJIANG	2011.01.05
C	ECN:C140183 MODIFY RATING	CAOCHEN	2014.08.07
D	ECN:C140262 MODIFY DRAWING	CAOCHEN	2014.12.01

SPECIFICATIONS:

- ELECTRICAL CHARACTERISTICS:
  - 1-1. RATING: 30V 4A
  - 1-2. CONTACT RESISTANCE: 30mΩ MAX.(INITIAL)
  - 1-3. DIELECTRIC WITHSTANDING VOLTAGE: 500V AC FOR ONE MINUTE.
  - 1-4. INSULATION RESISTANCE: 100MΩ MIN. MEASURED BY 500 VDC
- MECHANICAL CHARACTERISTICS:
  - 2-1. INSERTION FORCE : 0.2~2.5 KGF.
  - 2-2. WITHDRAWAL FORCE : 0.2~2.5KGF.
- LIFE TEST: 5,000 CYCLES.
- OTHER GENERAL SPEC. TO REFER "2DC-0018-020F SPEC".
- TO CONFORM TO SINGATRON HAZARDOUS SUBSTANCE FREE SPEC.
- HALOGEN FREE PRODUCT IDENTIFICATION MARK ON JACK:
- HALOGEN FREE PRODUCT IDENTIFICATION LABEL ON PACKAGING:
- FOR WAVE SOLDERING LEAD-FREE PROCESS.
- PACKAGING: TAPE & REEL

DATE CODE  
 YY: YEAR  
 MM: MONTH  
 DD: DATE

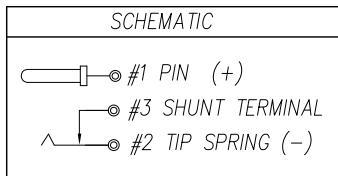
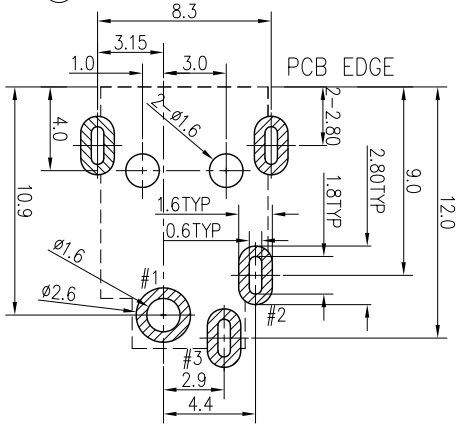
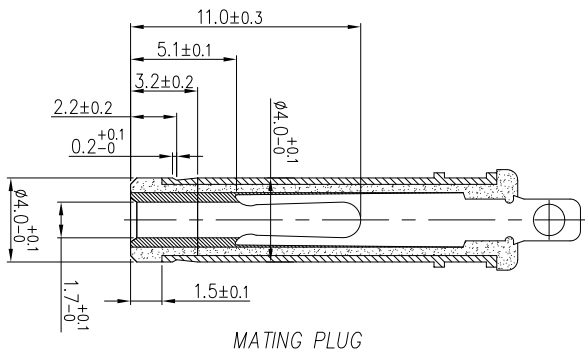
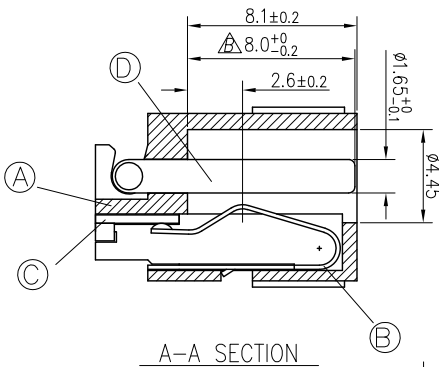
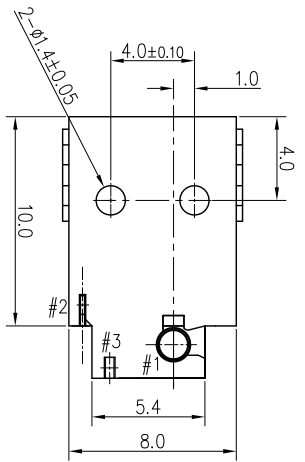
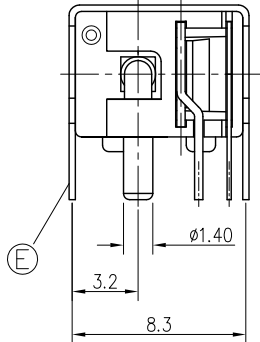
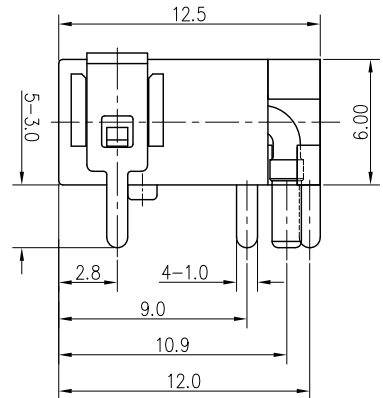
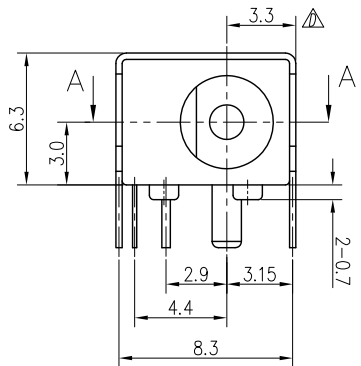
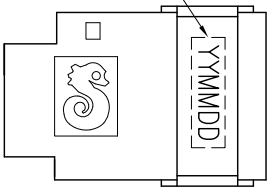

NO	DESCRIPTION	QTY	MATERIAL	PLATING & COLOR
E	SHIELD	1	BRASS BAR	Ni PLATING
D	PIN	1	BRASS BAR	Ni PLATING
C	SHUNT TERMINAL	1	BRASS 0.4t	Ag PLATING
B	TIP SPRING	1	COPPER ALLOY 0.2t	Ag PLATING
A	BODY	1	HI-TEMP.THERMOPLASTIC UL94V-0	BLACK COLOR

UNLESS OTHERWISE SPECIFIED TOLERANCES

Singatron Enterprise Co., Ltd.  
 信音企業股份有限公司

DECIMALS:	ANGLES:	TITLE	DC POWER JACK	
X : ±0.5	X : ±2°	DWN	CoaChen 14/12/09	<b>PART NO. 2DC-0018-012</b>
XX : ±0.3	XX : ±1°	CHKD	BILLY 14/12/09	SCALE 4:1 UNIT: mm
XXX : ±0.2		APVD	ZJZ 14/12/09	SIZE: A3 SHEET: 10F1 <b>REV: D</b>
<b>CUSTOMER COPY</b>				