

DATE CODE  
 YY:Year(07)  
 MM:Month(01~12)  
 DD:Day(01~31)

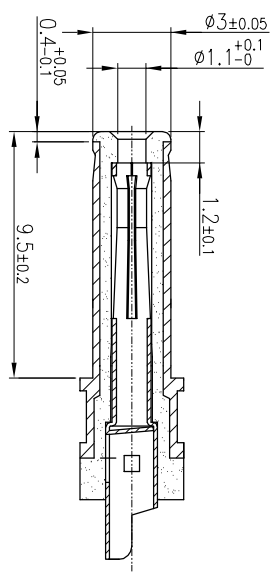

**Mating Plug only SINGATRON**  
**PART NO. ZDP-0053-K02**

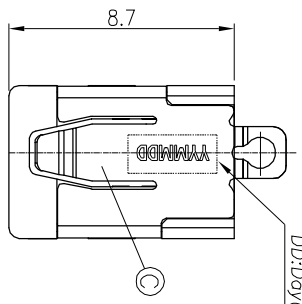
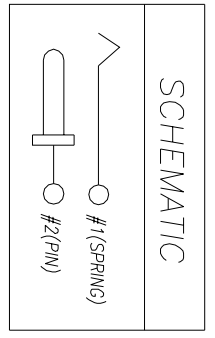
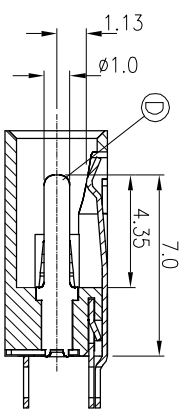
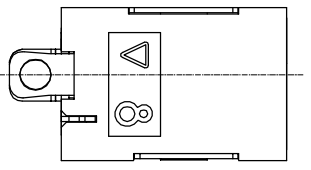
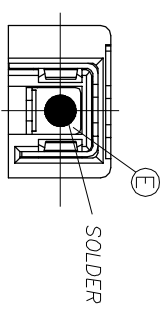
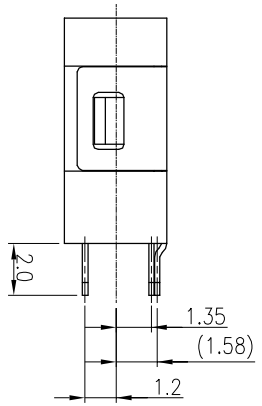

REV.	ECN NO.	OR DESCRIPTION	REVISED	DATE
B	ECN NO: T080106		EVEN	2008.06.19
C	ECN NO: T080116		EVEN	2008.07.01
D	ECN NO: S1206A2		ANDY	2012.12.14
E	ECN NO: S170135-Q		YUREN	2017.4.27
F	ECN NO: S180961-R		XUEHUA	2018.09.28

- SPECIFICATIONS:
- INSERTION FORCE: 0.6KG~2.0KG
  - WITHDRAWAL FORCE: 0.4KG~2.0KG
  - INSULATION RESISTANCE BETWEEN ANY ADJACENT TERMINALS SHALL NOT BE LESS THAN 100 MΩ AT 500 VDC.
  - JACK SHALL WITHSTAND 500 VOLTS BETWEEN ANY ADJACENT TERMINAL FOR ONE MINUTE.
  - CONTACT RESISTANCE SHALL NOT EXCEED 100mΩ
  - JACK SHALL WITHSTAND 10000 CYCLES OF INSERTION AND WITHDRAWAL WITH TESTING PLUG, AND CONTACT RESISTANCE SHALL NOT EXCEED 100mΩ
  - RATING: DC 12V 3A DEPAND ON MATING
  - 7.TO CONFORM TO SINGATRON HAZARDOUS SUBSTANCE FREE SPEC.
  - 8.GREEN PRODUCT IDENTIFICATION MARK ON JACK:
  - 9.GREEN PRODUCT IDENTIFICATION LABEL ON PACKAGING:
  - 10.PACKAGING: BAG.
  11. FOR REFLOW SOLDERING LEAD-FREE PROCESS.

**G.P. PASS**

E	TERMINAL	1	COPPER ALLOY 0.2t	可焊Ni 60μ"Min
D	PIN	1	BRASS BAR	GOLD FLASH(1u" Min)
C	SHELL	1	COPPER ALLOY 0.2t	可焊Ni 50u" Min
B	SPRING	1	COPPER ALLOY 0.2t	GOLD FLASH ONCONTACT AREAS AND SOLDER TAIL(ONVER Ni 50u" Min)
A	BODY	1	HIGH TEMP. THERMOPLASTIC UL 94V-0	BLACK COLOR
NO	DESCRIPTION	QTY	MATERIAL	PLATING & COLOR
UNLESS OTHERWISE SPECIFIED TOLERANCES				
Singatron Enterprise Co., Ltd. 信晉企業股份有限公司				
TITLE: DC POWER JACK				
DWN	XUEHUA	PART NO.	ZDC-0053-K08	
CHKD	RON	SCALE	5:1	UNIT: mm
APVD	LUSSENI	SIZE:	A3	SHEET: 1 OF 1
REV: F				
CUSTOMER COPY				

