

REV.	ECN NO.	OR DESCRIPTION	REVISED	DATE
D	ECN NO.S081023		Swina	2008.11.07
E	ECN NO.S100329		ANGEL	2010.04.21
F	ECN NO.S120741		ANDY	2012.09.04

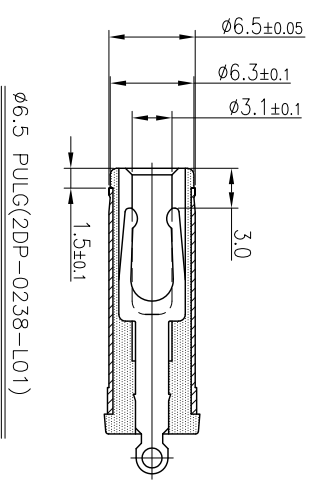

SPECIFICATIONS:

- RATING: DC 20V 8A
- INSERTION FORCE: 1.0Kg~2.5Kg
WITHDRAWAL FORCE: 1.0Kg~2.5Kg
- INSULATION RESISTANCE BETWEEN ANY ADJACENT TERMINALS SHALL NOT BE LESS THAN 100 MEGOHMS BY 500 VOLTS MEGGER.
- JACK SHALL WITHSTAND 500 VOLTS BETWEEN ANY ADJACENT TERMINAL FOR ONE MINUTE.
- CONTACT RESISTANCE SHALL NOT EXCEED 30mΩ
- JACK SHALL WITHSTAND 5,000 CYCLES OF INSERTION AND WITHDRAWAL WITH TESTING PLUG, AND CONTACT RESISTANCE SHALL NOT EXCEED 100mΩ
- MEASURING CONDITION:
TEMPERATURE: FROM 5°C TO 35°C.
RELATIVE HUMIDITY: FROM 40% TO 85%.
- SOLDER HEAT RESISTANCE: WAVE SOLDERING 260°C 10SECS.
- TO CONFORM TO SINGATRON HAZARDOUS SUBSTANCE FREE SPEC.
- GREEN PRODUCT IDENTIFICATION MARK ON JACK:
- GREEN PRODUCT IDENTIFICATION LABEL ON PACKAGING: **G.P. PASS**
- FOR LEAD-FREE PROCESS
- PRINTED DATE CODE "YYMMDD" ON TOP OF CONNECTOR.

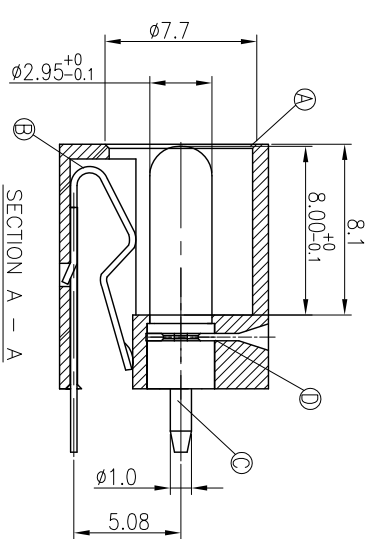
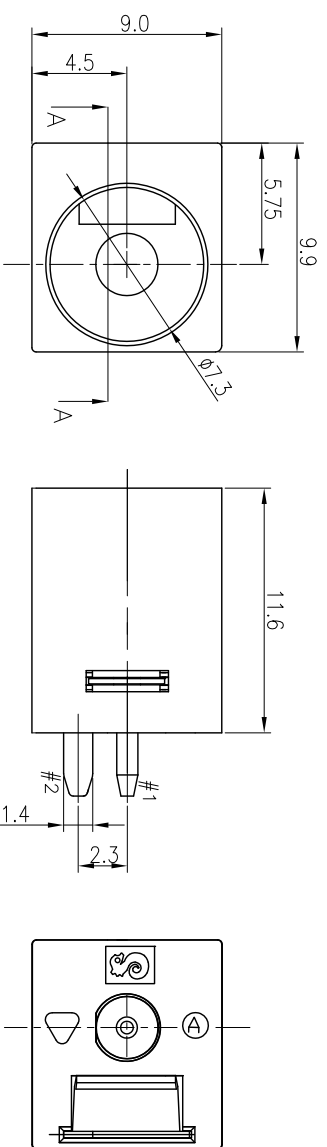
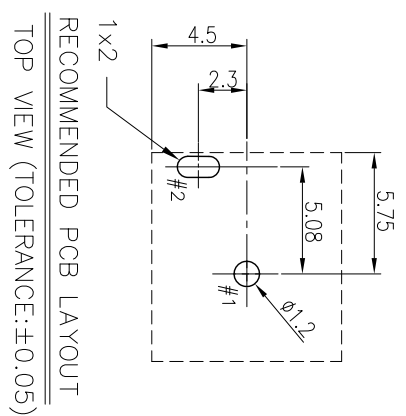
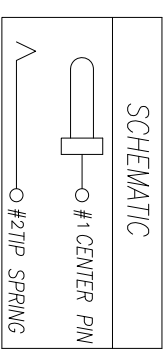

YYMMDD
DD: DAY
MM: MONTH
YY: YEAR

D	TERMINAL	1	STAINLESS 0.3T	N/A
C	PIN	1	BRASS BAR	可焊 Ni: 60U" Min
B	TIP	1	COPPER ALLOY 0.3t	Ag20U" Min Over Ni: 60U" Min
A	BODY	1	HIGH TEMPERATURE UL94V-0	BLACK
NO	DESCRIPTION		QTY MATERIAL	PLATING & COLOR

UNLESS OTHERWISE SPECIFIED TOLERANCES

DECIMALS:	ANGLES:
X : ±0.5	X : ±2°
X.X : ±0.3	X.X : ±1°
X.XX : ±0.2	

TITLE	DC POWER JACK
DWN	ADNY
CHKD	TOM
APVD	QUAN
SCALE: 4:1	
UNIT: mm	
SIZE: A3	
SHEET: 1 OF 1	
REV: F	

CUSTOMER COPY

Singatron Enterprise Co., Ltd.
信音企業股份有限公司