

REV.	ECN NO OR DESCRIPTION	REVISED	DATE
E	2070091 CHANGE PIN HEAD FROM FULL R TO H	HANJIA	6/27/07
F	ADD GREEN PRODUCT IDENTIFICATION MARK	KENSON	8/18/09

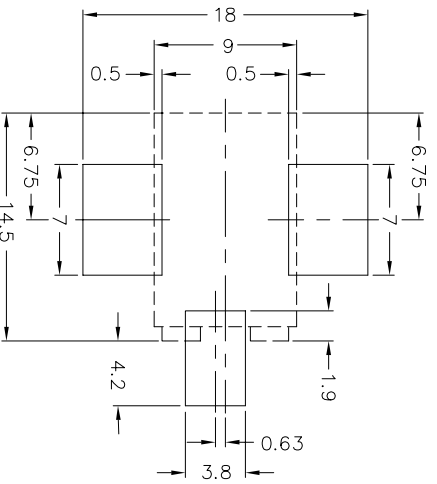
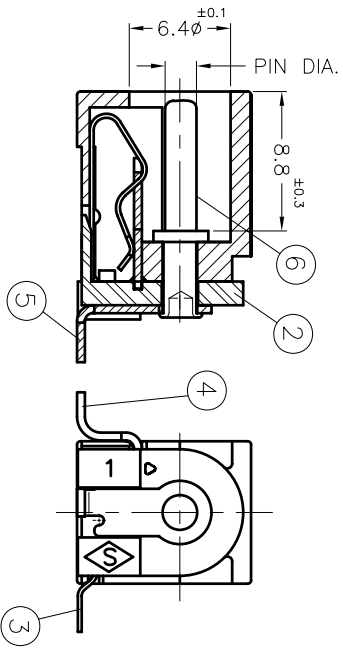
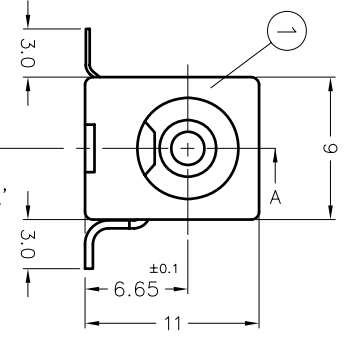
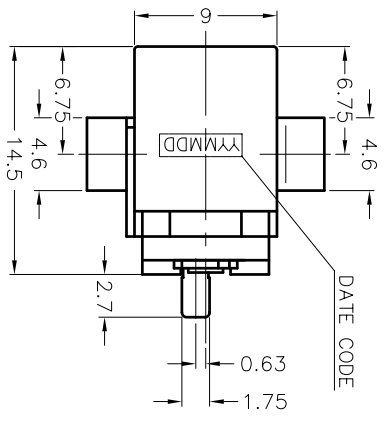

2DC-0405 200

PART NO.	PIN DIA.
B	φ2.5 +0/-0.1
C	φ2.35 +0/-0.1
D	φ2.0 +0/-0.1
F	φ1.87 +0/-0.1
G	φ1.45 +0/-0.1

- SPECIFICATIONS:
- RATING: DC 16V 3A
 - INSERTION FORCE: 0.2KG-2KG
WITHDRAWAL FORCE: 0.2KG-1.5KG
 - INSULATION RESISTANCE BETWEEN ANY ADJACENT TERMINALS SHALL NOT BE LESS THAN 100 MEGOHMS BY 500 VOLTS MEGGER.
 - JACK SHALL WITHSTAND 250 VOLTS BETWEEN ANY ADJACENT TERMINAL FOR ONE MINUTE.
 - CONTACT RESISTANCE SHALL NOT EXCEED 0.03 OHMS.
 - JACK SHALL WITHSTAND 5,000 CYCLES OF INSERTION AND WITHDRAWAL WITH TESTING PLUG, AND CONTACT RESISTANCE SHALL NOT EXCEED 0.1 OHMS.
 - MEASURING CONDITION:
TEMPERATURE: FROM 5°C TO 35°C.
RELATIVE HUMIDITY: FROM 40% TO 85%.
 - ENVIRONMENTAL SPECIFICATIONS:
 - HUMIDITY TEST: HUMIDITY 90% TO 95% TEMPERATURE 40°C ±2°C FOR 96 HOURS.
 - HEAT TEST: TEMPERATURE 70°C ± 2°C (HUMIDITY BELOW 50%) FOR 96 HOURS.
 - COLD TEST: TEMPERATURE -40°C ± 2°C FOR 96 HOURS.
 - PACKING: TAPE & REEL
 - TO CONFORM TO THE SINGATRON HSF SPECIFICATION.
 - GREEN PRODUCT IDENTIFICATION MARK ON JACK:
 - GREEN PRODUCT IDENTIFICATION LABEL ON PACKING:
 - DATE CODE DESCRIPTION:

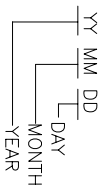

NO	DESCRIPTION	MATERIAL	PLATING/COLOR
F	PIN	BRASS BAR	NICKEL PLATING
E	TERMINAL	BRASS 0.5T	SILVER PLATING
D	SHUNT TERMINAL	BRASS 0.5T	SILVER PLATING
C	TIP SPRING	BERYLLIUM 0.25T	SILVER PLATING
B	COVER	PA9T+30%GF UL94V-0	BLACK COLOR
A	BODY	PA9T+30%GF UL94V-0	BLACK COLOR

UNLESS OTHERWISE SPECIFIED TOLERANCES

Singatron Electronic(Chung-Shan) Co., Ltd.
信音電子(中山)有限公司

DECIMALS:	ANGLES:	TITEL
X :±0.5	X :±2°	DC POWER JACK
X.X :±0.3	X.X :±1°	DWN KENSON 8/18/09 PART NO. 2DC-0405 200
X.XX :±0.2		CHKD HARVEY SCALE: N/A UNIT: mm
		APVD ROBIN SIZE: A3 SHEET: 10F1 REV: F

CUSTOMER COPY