

REV.	ECN NO OR DESCRIPTION	REVISED	DATE
A	PRODUCT RELEASE	JUN HUA	6/27/07
B	零件規格更改位置	KENSON	8/18/09

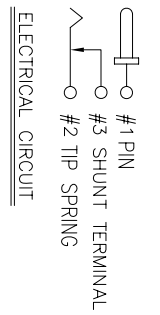
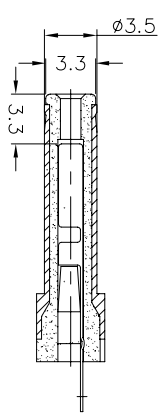
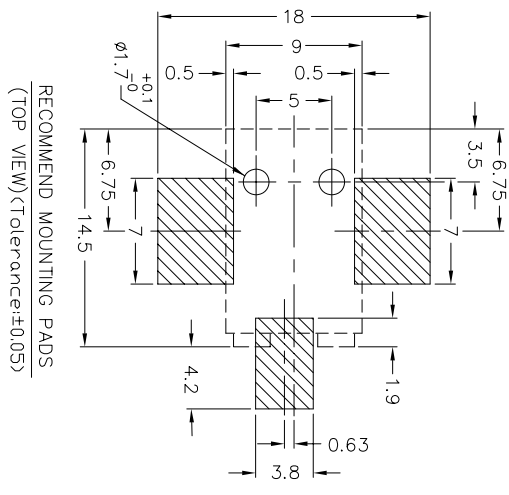
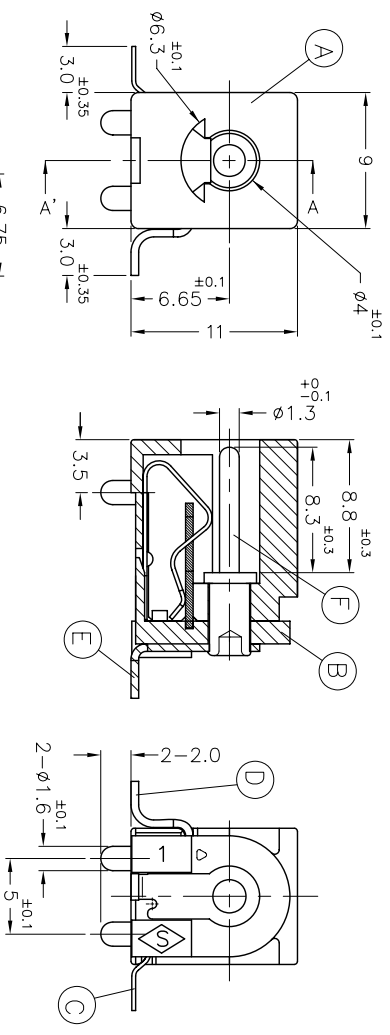
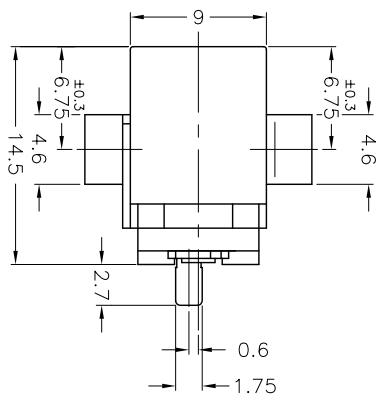

- SPECIFICATIONS:
- RATING: DC 16V 3A
 - INSERTION FORCE: 0.3KG-2KG
 - WITHDRAWAL FORCE: 0.3KG-1.5KG
 - INSULATION RESISTANCE BETWEEN ANY ADJACENT TERMINALS SHALL NOT BE LESS THAN 100 MEGOHMS BY 500 VOLTS MEGGER.
 - JACK SHALL WITHSTAND 250 VOLTS BETWEEN ANY ADJACENT TERMINAL FOR ONE MINUTE.
 - CONTACT RESISTANCE SHALL NOT EXCEED 0.03 OHMS.
 - JACK SHALL WITHSTAND 5,000 CYCLES OF INSERTION AND WITHDRAWAL WITH TESTING PLUG AND CONTACT RESISTANCE SHALL NOT EXCEED 0.1 OHMS.
 - MEASURING CONDITION: FROM 5°C TO 35°C. TEMPERATURE: RELATIVE HUMIDITY: FROM 40% TO 85%.
 - ENVIRONMENTAL SPECIFICATIONS:
 - HUMIDITY TEST: HUMIDITY 90% TO 95% TEMPERATURE 40°C ± 2°C FOR 96 HOURS.
 - HEAT TEST: TEMPERATURE 70°C ± 2°C (HUMIDITY BELOW 50%) FOR 96 HOURS.
 - COLD TEST: TEMPERATURE -40°C ± 2°C FOR 96 HOURS.
 - UNLESS OTHERWISE SPECIFIED TOLERANCE ARE: ±0.2
 - PACKING: TUBE
 - TO CONFORM TO THE SINGATRON HSF SPECIFICATION.
 - GREEN PRODUCT IDENTIFICATION MARK IN JACK:
 - GREEN PRODUCT IDENTIFICATION LABEL IN PACKING: **G.P. PASS**
 - FOR LEAD-FREE PRODUCT.
 - PACKAGE: TAPE&REEL

NO	DESCRIPTION	QTY	MATERIAL	PLATING & COLOR
F	PIN	1	BRASS BAR	NICKEL PLATING
E	TERMINAL	1	BRASS 0.5t	SILVER PLATING
D	SHUNT TERMINAL	1	BRASS 0.5t	SILVER PLATING
C	TIP SPRING	1	PHOSPHOR BRONZE 0.25t	SILVER PLATING
B	COVER	1	HIGH TEMP.THERMAL PLASTIC UL 94V-0	BLACK COLOR
A	BODY	1	HIGH TEMP.THERMAL PLASTIC UL 94V-0	BLACK COLOR

DECIMALS:	ANGLES:	TITLE
X : ±0.5	X : ±2°	D.C. POWER JACK
X.X : ±0.3	X.X : ±1°	
X.XX : ±0.2		

APVD	ROB/N	SCALE: N/A	SHEET: 10F1	REV: B

CUSTOMER COPY

Singatron Electronic(Chung-Shan) Co., Ltd.
 信登電子(中山)有限公司