

REV.	ECN NO OR DESCRIPTION	REVISED	DATE
A	PDR RELEASE	IVY-C	2010.02.08
B	ECN NO: L120156 (核准号)	IVY-C	2012.10.12

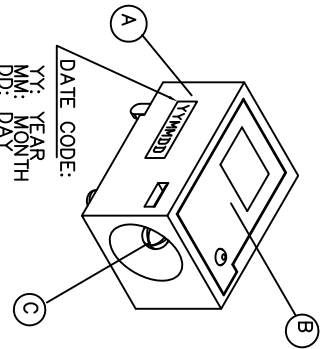

**SPECIFICATIONS:**

1. TO CONFORM TO SINGATRON HAZARDOUS SUBSTANCE FREE SPEC.
2. GREEN PRODUCT IDENTIFICATION LABEL ON PACKING **[GREEN PASS]**
3. SOLDER HEAT RESISTANCE : REFLOW SOLDER PROCESS 260°C 10 SECS.
4. OTHER GENERAL SPEC. TO REFER " DC POWER JACK SPEC"
5. PACKAGE: SEE " 2DC-B224-H13 " PACKAGE.

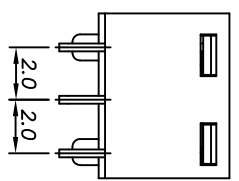
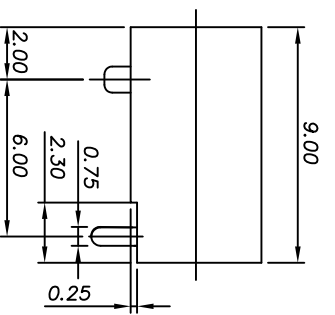
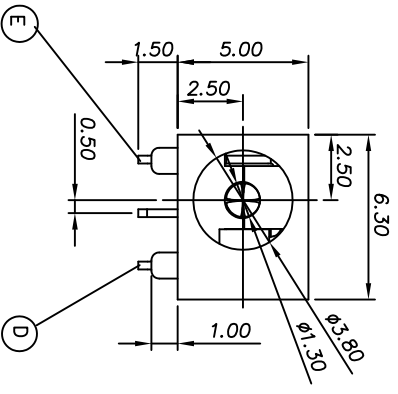
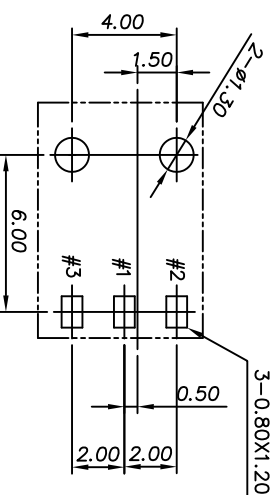
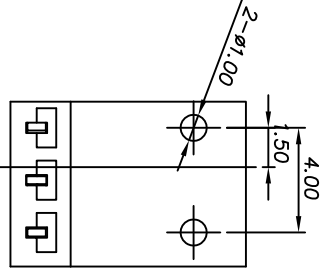

RECOMMENDED PCB LAYOUT  
 <TOP VIEW>  
 NOTE : TOLERANCE FOR PCB LAYOUT IS ± 0.05

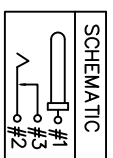
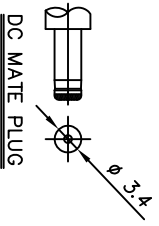

PART NO. **2DC-B224-H13**  
 PACKAGE & REEL  
 1: TAPE

NO	DESCRIPTION	QTY	MATERIAL	PLATING & COLOR
A	HOUSING	1	HIGH TEMP. THERMOPLASTIC UL 94V-0	BLACK COLOR
B	COVER	1	HIGH TEMP. THERMOPLASTIC UL 94V-0	BLACK COLOR
C	PN	1	COPPER ALLOY 0.3t	Ag PLATING
D	TIP (SPR CONTACT)	1	COPPER ALLOY 0.3t	Ag PLATING
E	SHUNT TERMINAL	1	COPPER ALLOY 0.3t	Ag PLATING

DECIMALS:	ANGLES:
X : ±0.5	X : ±2°
X.X : ±0.3	X.X : ±1'
X.XX : ±0.2	

TITLE	PART NO.
DC POWER JACK	<b>2DC-B224-H13</b>

DWN	CHKD	APVD	SCALE	UNIT	SIZE	SHEET	REV.
IVY-C-20121012	IVY-C-20121012	IVY-C-20121012	N/A	mm	A3	1 OF 1	B

CUSTOMER COPY

Singatron Enterprise Co., Ltd.  
 信音企業股份有限公司

