

| REV. | ECN NO. OR DESCRIPTION | REVISED | DATE |
|------|------------------------|---------|------------|
| C | ECN NO. S090318 | Samming | 2009.04.30 |
| D | ECN NO.:S120907 | SEAN | 2012.10.09 |
| E | ECN NO.:S120857 | ANDY | 2012.11.28 |

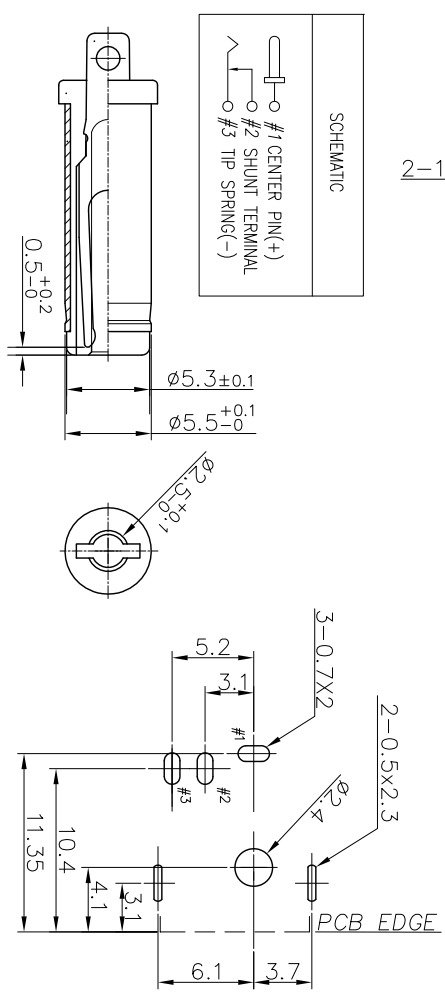
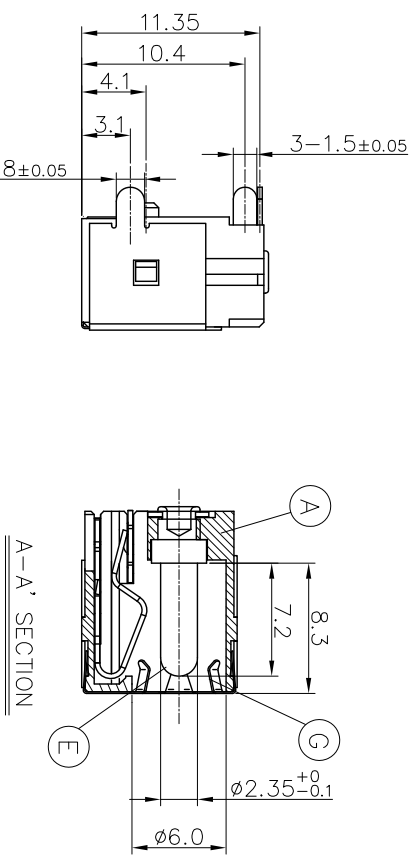
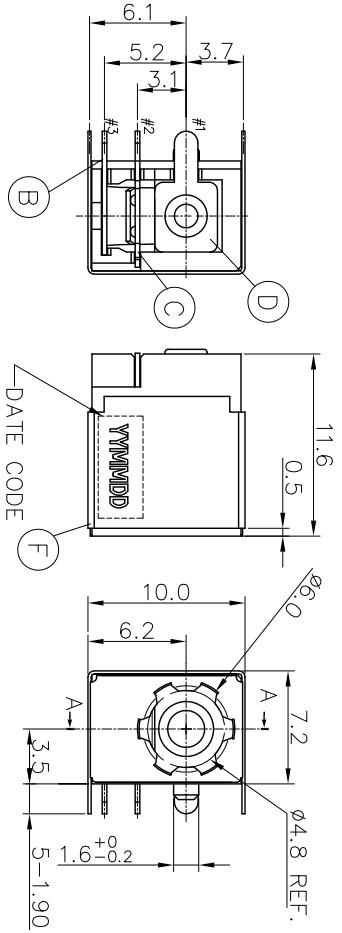

RECOMMENDED P.C.B LAYOUT THICKNESS: 1.2t
SOLDERING SIDE (TOLERANCE ±0.05)

- SPECIFICATIONS:**
1. RATING: DC 20V 4A
 2. INSERTION FORCE: 0.4KG-3.0KG WITHDRAWAL FORCE: 0.4KG-3.0KG
 3. INSULATION RESISTANCE BETWEEN ANY ADJACENT TERMINALS SHALL NOT BE LESS THAN 100 MEGOHMS BY 500 VOLTS MEGGER.
 4. JACK SHALL WITHSTAND 250 VOLTS BETWEEN ANY ADJACENT TERMINAL FOR ONE MINUTE.
 5. CONTACT RESISTANCE SHALL NOT EXCEED 30mΩ
 6. JACK SHALL WITHSTAND 5,000 CYCLES OF INSERTION AND WITHDRAWAL WITH TESTING PLUG AND CONTACT RESISTANCE SHALL NOT EXCEED 100mΩ
 7. MEASURING CONDITION: TEMPERATURE: FROM 5°C TO 35°C. RELATIVE HUMIDITY: FROM 40% TO 85%
 8. PACKAGING: TAPE & REEL.
 9. SOLDER HEAT RESISTANCE: PEAK TEMP. 260°C 10 SECS.
 10. TO CONFORM TO SINGATRON HAZARDOUS SUBSTANCE FREE SPEC.
 11. GREEN PRODUCT IDENTIFICATION MARK ON JACK:
 12. GREEN PRODUCT IDENTIFICATION LABEL ON PACKAGING: **G.P. PASS**
 13. FOR LEAD-FREE PROCESS.

| NO | DESCRIPTION | QTY | MATERIAL | PLATING & COLOR |
|----|------------------|-----|--------------------------|---------------------|
| G | GROUNDING SPRING | 1 | STAINLESS 0.1T | N/A |
| F | SHIELDING | 1 | BRASS STRIP 0.2t | NICKEL PLATING |
| E | PIN | 1 | BRASS BAR | NICKEL PLATING |
| D | TERMINAL | 1 | BRASS STRIP 0.3t | SILVER PLATING |
| C | SHUNT TERMINAL | 1 | BRASS STRIP 0.3t | SILVER PLATING |
| B | TIP SPRING | 1 | YCU1M-H 0.3T | Ag 20u" Over Ni20u" |
| A | BODY | 1 | HIGH TEMP. THERMOPLASTIC | BLACK COLOR |

UNLESS OTHERWISE SPECIFIED TOLERANCES:

| DECIMALS: | ANGLES: |
|-------------|-----------|
| X : ±0.5 | X : ±2° |
| X.X : ±0.3 | X.X : ±1' |
| X.XX : ±0.2 | |

TITLE: DC POWER JACK
PART NO. 2DC-G026-C02

Singatron Enterprise Co., Ltd.
信晉企業股份有限公司

CHKD TOM SCALE: 1:3 UNIT: mm
APVD MAX SIZE: A3 SHEET: 1 OF 1 REV: E

CUSTOMER COPY