

REV.	ECN NO. OR DESCRIPTION	REVISED	DATE
B	Correct Drawing	LIAO	2006.03.24
C	ECN-S091225	Soldier	2009.12.28

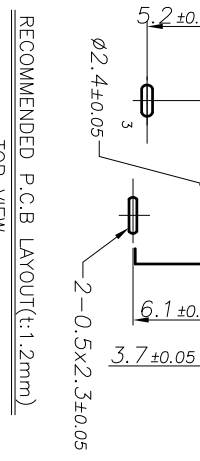
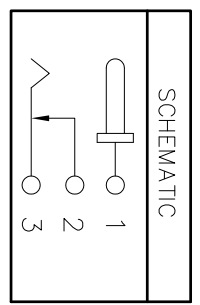
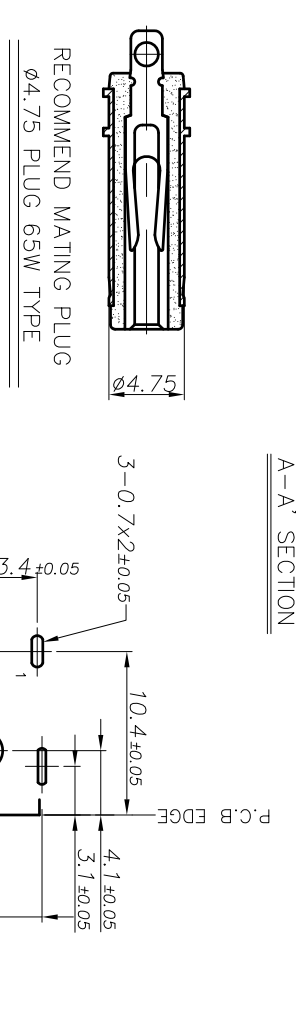
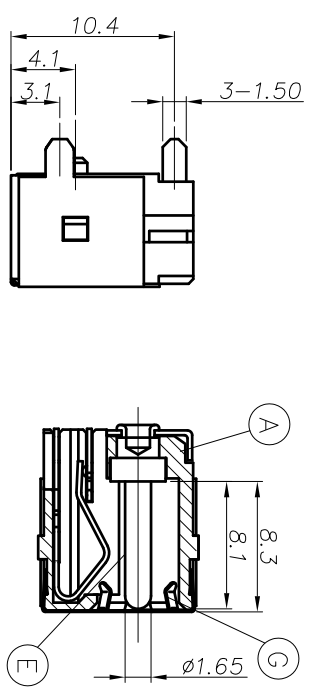
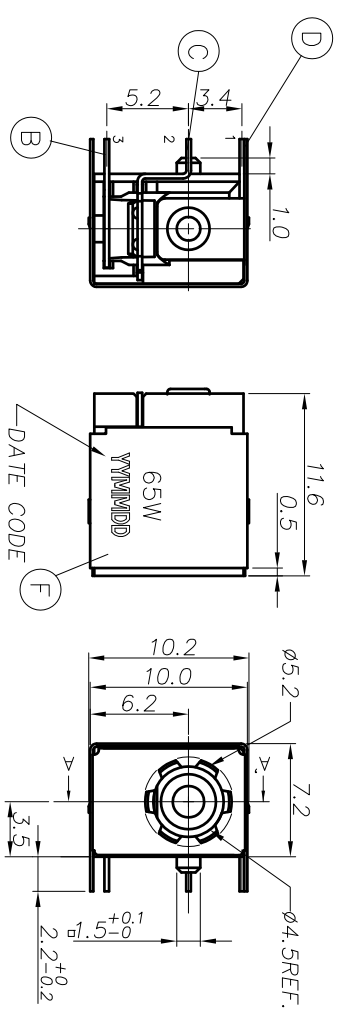

- SPECIFICATIONS:**
- RATING: DC 19V 5A
 - INSERTION FORCE: 0.4KG-3.0KG
 - WITHDRAWAL FORCE: 0.4KG-3.0KG
 - INSULATION RESISTANCE BETWEEN ANY ADJACENT TERMINALS SHALL NOT BE LESS THAN 100 MEGOHMS BY 500 VOLTS MEGGER.
 - JACK SHALL WITHSTAND 250 VOLTS BETWEEN ANY ADJACENT TERMINAL FOR ONE MINUTE.
 - CONTACT RESISTANCE SHALL NOT EXCEED 0.03 OHMS.
 - JACK SHALL WITHSTAND 5,000 CYCLES OF INSERTION AND WITHDRAWAL WITH TESTING PLUG, AND CONTACT RESISTANCE SHALL NOT EXCEED 0.1 OHMS.
 - MEASURING CONDITION:
TEMPERATURE: FROM 5°C TO 35°C.
RELATIVE HUMIDITY: FROM 40% TO 85%
 - ENVIRONMENTAL SPECIFICATIONS:
8.1 HUMIDITY TEST: HUMIDITY 90% TO 95% TEMPERATURE 40°C ± 2°C FOR 96 HOURS.
8.2 HEAT TEST: TEMPERATURE 70°C ± 2°C (HUMIDITY BELOW 50%) FOR 96 HOURS.
8.3 COLD TEST: TEMPERATURE -40°C ± 2°C FOR 96 HOURS.
 - SOLDERABILITY TEST: THE TERMINATION IS AT LEAST 95% COVERED BY A CONTINUOUS NEW SOLDER COATING.
TEST CONDITION: DIP IN MOLTEN SOLDER FOR 5 Sec. AT 245±5°C (TERMINATION SHALL BE IMMersed IN FLUX BEFORE TEST)
 - PACKAGING: TAPE & REEL
 - SOLDERING CONDITION: WAVE SOLDERING / IR REFLOW.
 - TO CONFORM TO SINGATRON HAZARDOUS SUBSTANCE FREE SPECIFICATION.
 - GREEN PRODUCT IDENTIFICATION MARK ON JACK: **G.P. PASS**
 - GREEN PRODUCT IDENTIFICATION LABEL ON PACKAGING:
15 REPRESENT CRITICAL DIMENSIONS.

NO	DESCRIPTION	QTY	MATERIAL	PLATING & COLOR
A	BODY	1	PA-9T+30%GF	BLACK COLOR
B	TIP SPRING	1	COPPER ALLOY 0.3t	
C	SHUNT TERMINAL	1	BRASS STRIP 0.3t	Ag 20u" Over Ni60u"
D	TERMINAL	1	BRASS STRIP 0.3t	
E	PN	1	BRASS BAR	Ni 60u" Min
F	SHIELDING	1	BRASS STRIP 0.2t	
G	GROUND SPRING	1	STAINLESS 0.1t	N/A

DECIMALS:	ANGLES:	TITLE	DC POWER JACK
X : ±0.5	X : ±2°	DWN	Solder
X.X : ±0.3	X.X : ±1°	CHKD	LUSSSEN
X.XX : ±0.2		APVD	TONY

PART NO.	SCALE:	UNIT:	SHEET:	REV:
2DC-G026-109	3/4	mm	1 OF 1	C

CUSTOMER COPY

Singatron Enterprise Co., Ltd.
信登企業股份有限公司