

REV.	ECN NO OR DESCRIPTION	REVISED	DATE
C	ECN NO.S100930	ANDY	2010.11.08
D	ECN NO.S150539-Q	YUREN	2015.07.24
E	ECN NO.S150941-E	YUREN	2015.12.11

SPECIFICATIONS:

- INSERTION FORCE: 3.0KG MAX.  
WITHDRAWAL FORCE: 1.0KG-3.0KG
- INSULATION RESISTANCE BETWEEN ANY ADJACENT TERMINALS SHALL NOT BE LESS THAN 100 MEGOHMS BY 500 VOLTS MEGGER.
- JACK SHALL WITHSTAND 250 VOLTS BETWEEN ANY ADJACENT TERMINAL FOR ONE MINUTE.
- CONTACT RESISTANCE SHALL NOT EXCEED 20mΩ
- JACK SHALL WITHSTAND 5,000 CYCLES OF INSERTION AND WITHDRAWAL WITH TESTING PLUG, AND CONTACT RESISTANCE SHALL NOT EXCEED 30mΩ
- MEASURING CONDITION:  
TEMPERATURE: FROM 5°C TO 35°C.  
RELATIVE HUMIDITY: FROM 40% TO 85%.
- ENVIRONMENTAL SPECIFICATIONS:
  - HUMIDITY TEST: HUMIDITY 90% TO 95% TEMPERATURE 40°C ±2°C FOR 96 HOURS.
  - HEAT TEST: TEMPERATURE 70°C ± 2°C (HUMIDITY BELOW 50%) FOR 96 HOURS.
  - COLD TEST: TEMPERATURE -40°C ± 2°C FOR 96 HOURS.
- PACKAGING: TRAY
- PRINTED DATE CODE "YYMMDD" ON TOP OF CONNECTOR.
 

YYMMDD

  - DD: DAY
  - MM: MONTH
  - YY: YEAR
- MATING PLUG : SINGATRON'S P/N : 2DP-G213-B04(PLUG SET)
- SOLDER HEAT RESISTANCE: WAVE SOLDERING 260°C 10 SECS.
- TO CONFORM TO SINGATRON HAZARDOUS SUBSTANCE FREE SPEC.
- GREEN PRODUCT IDENTIFICATION MARK ON JACK:
- GREEN PRODUCT IDENTIFICATION LABEL ON PACKAGING: G.P. PASS
- FOR WAVE SOLDERING LEAD-FREE PROCESS.

RECOMMEND P.C.B LAYOUT

TOP VIEW (TOLERANCE ±0.05)

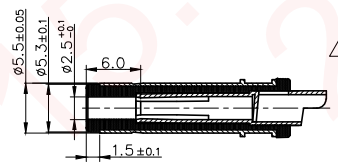
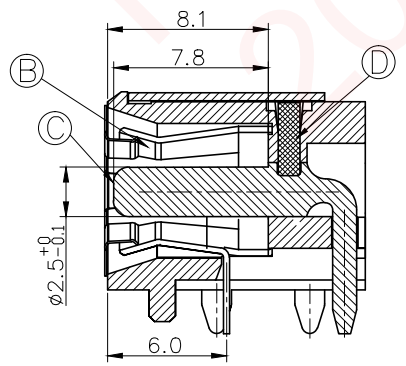
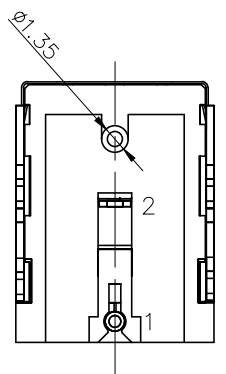
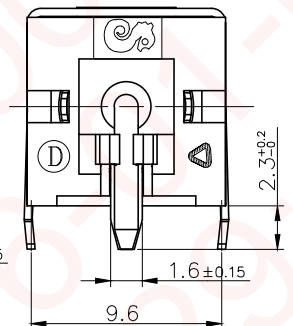
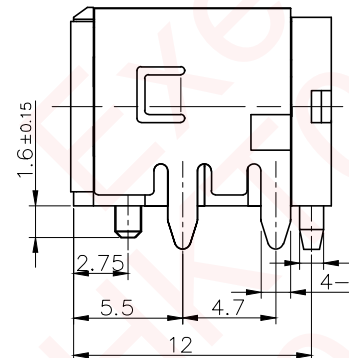
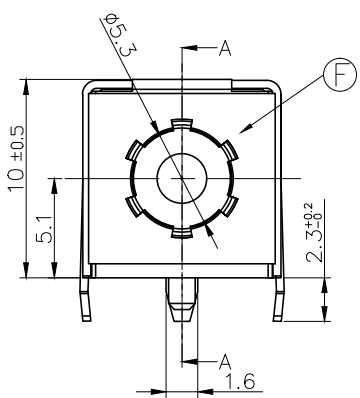
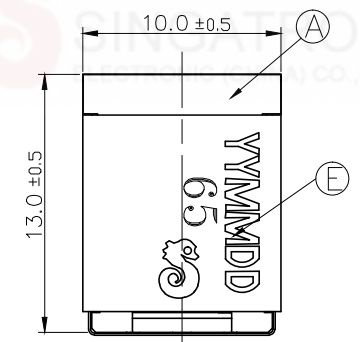
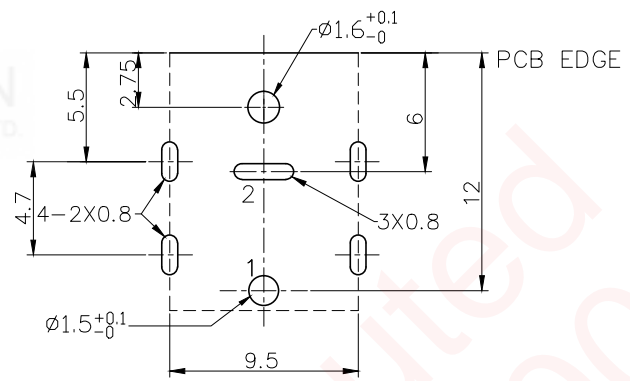

Ø5.5 PULG TYPE(2DP-G213-B04)  
1.RATING: DC 20V 10A 44uF

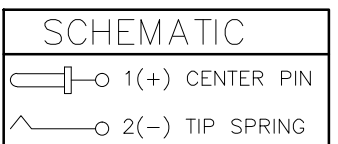

NO	DESCRIPTION	QTY	MATERIAL	PLATING & COLOR
F	GROUND	1	STAINLESS 0.15t	N/A
E	SHELL	1	COPPER ALLOY 0.4t	Ni 60u" Min
D	STOPPER	1	HIGH TEMP. THERMOPLASTIC UL 94V-0	NATURE
C	PIN	1	BRASS BAR	Ag20u" On Contact Area, Cu60u" On Solder All Over Ni60u"
B	SPRING	1	COPPER ALLOY 0.3t	Sn60u" On Contact Area, Cu60u" On Solder All Over Ni60u"
A	BODY	1	HIGH TEMP. THERMOPLASTIC UL 94V-0	BLACK

UNLESS OTHERWISE SPECIFIED TOLERANCES		Singatron Enterprise Co., Ltd. 信音企業股份有限公司	
DECIMALS:	ANGLES:	TITLE DC POWER JACK	
X :±0.5	X :±2°	DWN	YUREN PART NO. 2DC-G213-B52
X.X :±0.3	X.X :±1°	CHKD	CERRY SCALE:4:1 UNIT: mm
X.XX :±0.2		APVD	LIAO SIZE: A3 SHEET:1 OF 1 REV:E
CUSTOMER COPY			