

REV.	ECN NO OR DESCRIPTION	REVISED	DATE
A	PDR NO:1151210-4A	Allen	2016.10.21
B	ECN NO:S180866-E / Δ	Springwu	2019.1.10

1. GROUND接觸狀態

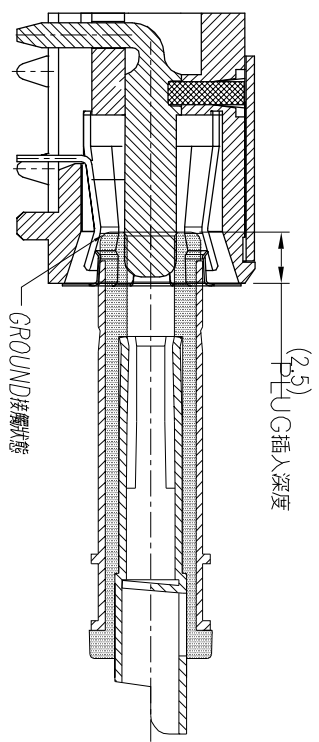

4. LOCK狀態

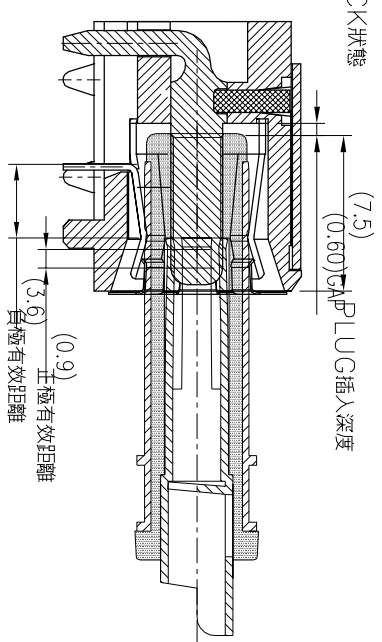

2. SPRING(-)接觸狀態

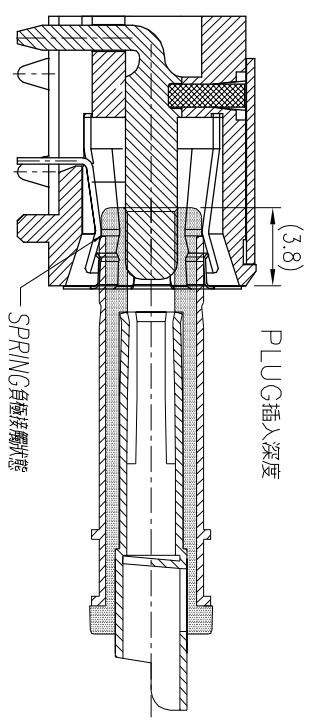

5. PLUG插至定位狀態

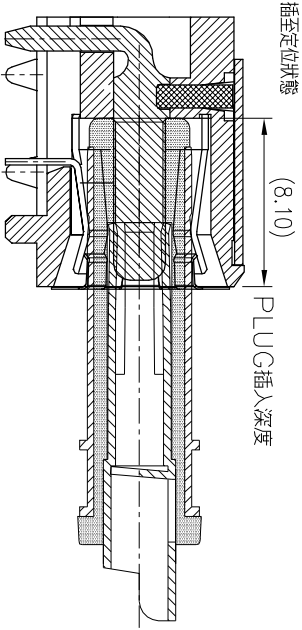

3. 正極 (PIN) 接觸狀態

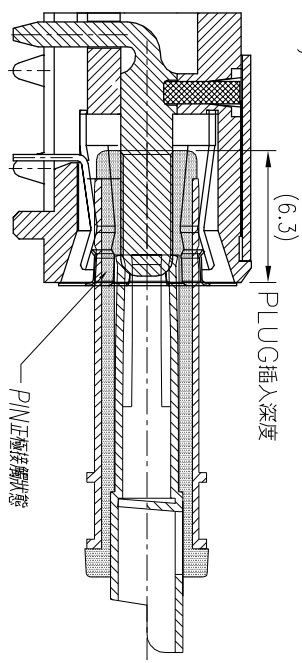

NO	DESCRIPTION	QTY	MATERIAL	PLATING & COLOR
	UNLESS OTHERWISE SPECIFIED TOLERANCES		信晉企業股份有限公司	
	DECIMALS:		ANGLES:	
X	:±0.5	X	:±2°	
X.X	:±0.3	X.X	:±1°	
X.XX	:±0.2			
	TITLE	MATING		
DWN	Springwu	PART NO.	2DC-G213-B78F	
CHKD	Sky	SCALE:4:1	UNIT:	mm
APVD	Lussen	SIZE: A3	SHEET:2 OF 2	REV:B

CUSTOMER COPY