

- SPECIFICATIONS:**
- ELECTRICAL CHARACTERISTICS:**
 - RATING: DC 20V 10A.
 - CONTACT RESISTANCE: 30m Ω MAX.
 - DIELECTRIC WITHSTANDING VOLTAGE: 150V AC FOR ONE MINUTE.
 - INSULATION RESISTANCE: 100M Ω MIN. MEASURED BY 500 VDC.
 - MECHANICAL CHARACTERISTICS:**
 - INSERTION FORCE : 3.0 KGF Max.
 - WITHDRAWAL FORCE : 0.3~3.0 KGF.
 - LIFE TEST: 5,000 CYCLES MIN.
 - OTHER GENERAL SPEC. TO REFER "2DC-G213-B83F SPEC."
 - TO CONFORM TO SINGATRON HAZARDOUS SUBSTANCE FREE SPEC.
 - HALOGEN FREE PRODUCT IDENTIFICATION MARK ON PRODUCT:
 - HALOGEN FREE PRODUCT IDENTIFICATION LOGO ON THE PACKAGING:
 - FOR REFLOW SOLDERING LEAD-FREE PROCESS.

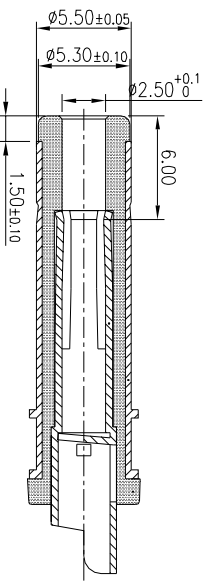

ø5.5 PLUG TYPE(ZDP-G213-B04)

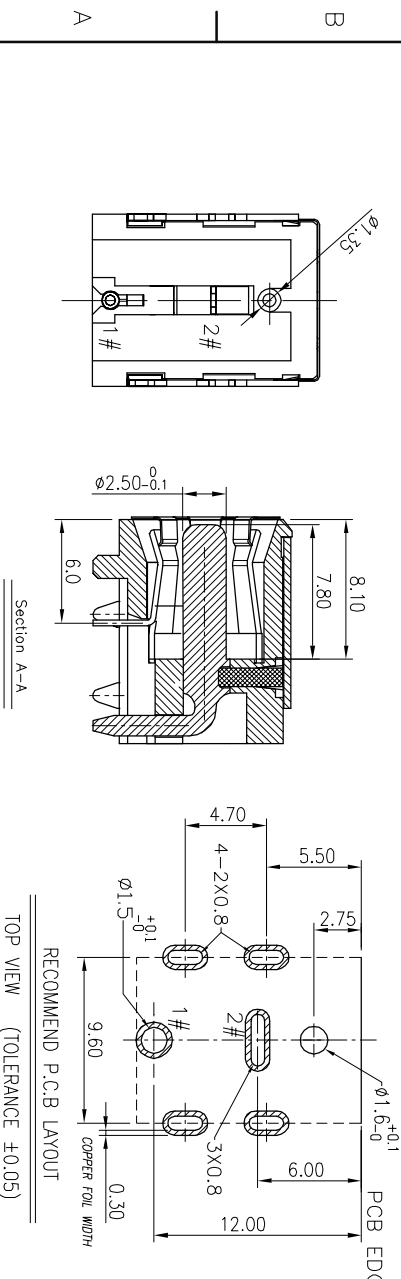

NO	DESCRIPTION	QTY	MATERIAL	PLATING & COLOR
F	GROUND	1	STAINLESS 0.15I	N/A
E	SHELL	1	SPCC-SD 0.4T	#6W/ 60U" Min. OVER CU 80U" Min.
D	STOPPER	1	HIGH TEMP.THERMOPLASTIC UJ 94V-0	BLACK
C	PIN	1	2.5øHB59-1.5B	Au 30U" OVER Ni 50U" Min.
B	SPRING	1	COPPER ALLOY 0.3I	Sn 60U" OVER Ni 60U"
A	BODY	1	PA10T UJ94V-0	BLACK
NO	DESCRIPTION <td>QTY <td>MATERIAL</td> <td>PLATING & COLOR</td> </td>	QTY <td>MATERIAL</td> <td>PLATING & COLOR</td>	MATERIAL	PLATING & COLOR
UNLESS OTHERWISE SPECIFIED TOLERANCES				
Singatron Enterprise Co., Ltd. 信登企業股份有限公司				
TITLE: DC POWER JACK				
DWN	Springwu	PART NO.	2DC-G213-B83F	
CHKD	Sky	SCALE:4:1	UNIT: mm	
APVD	Lussen	SIZE: A3	SHEET:1 OF 2	REV:C
CUSTOMER COPY				



1. GROUND接觸狀態

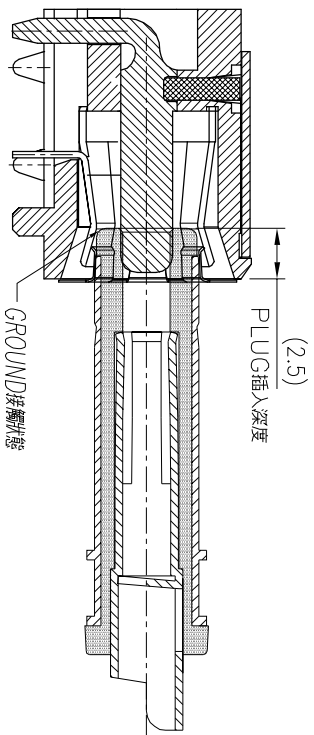

2. SPRING(-) 接觸狀態

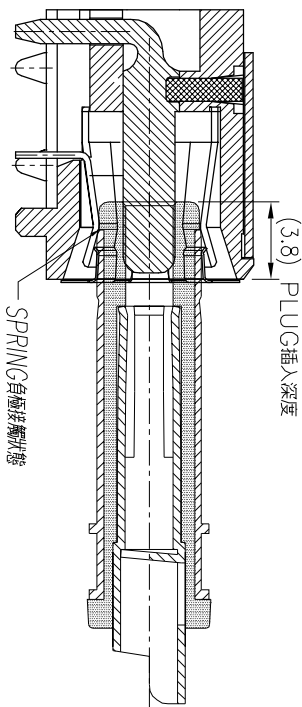

3. 正極 (PIN) 接觸狀態

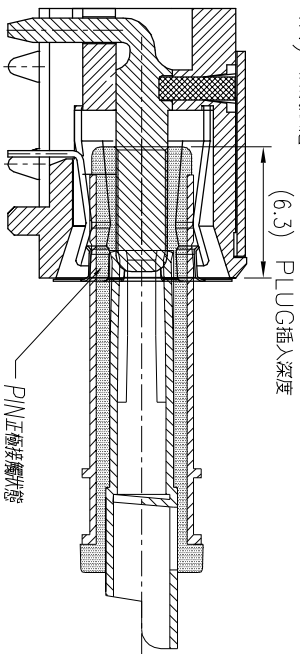

4. LOCK狀態

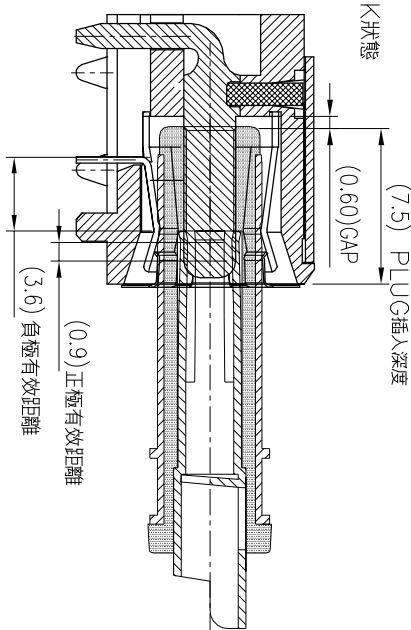

5. PLUG插至定位狀態

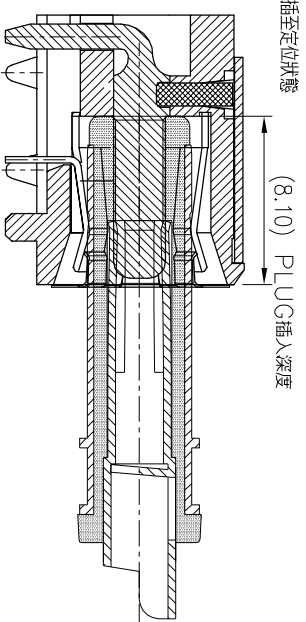

REV.	ECN NO. OR DESCRIPTION	REVISED	DATE
A	PDR NO.:T161014-2A	Wenshuo	2017.02.17
B	ECN NO.:S1B0866-E	Springwu	2019.1.9
C	ECN NO.:S190534-E	Springwu	2019.8.1

NO	DESCRIPTION	QTY	MATERIAL	PLATING & COLOR
UNLESS OTHERWISE SPECIFIED TOLERANCES				
DECIMALS:	ANGLES:			
X :±0.5	X :±2°			
X.X :±0.3	X.X :±1°			
X.XX :±0.2				
TITLE	MATING			
DWM Springwu	PART NO. 2DC-G213-B83F			
CHKD Sky	SCALE:4:1 UNIT: mm			
APVD Lussen	SIZE: A3 SHEET: 2 OF 2 REV: C			

CUSTOMER COPY