

For ECS only

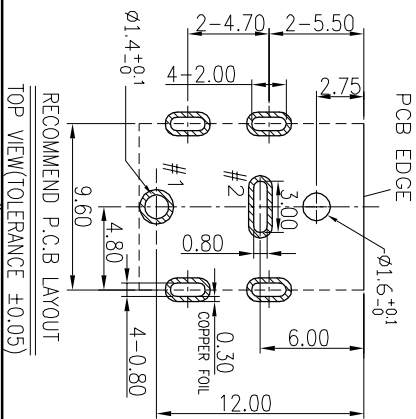

SPECIFICATIONS:

- ELECTRICAL CHARACTERISTICS:
 - RATING: 20V 10A
 - CONTACT RESISTANCE: 30mΩ MAX.
 - DIELECTRIC WITHSTANDING VOLTAGE: 500V AC FOR ONE MINUTE.
 - INSULATION RESISTANCE: 100MΩ MIN. MEASURED BY 500 VDC
- MECHANICAL CHARACTERISTICS:
 - INSERTION FORCE : 3.5 kg Max.
 - WITHDRAWAL FORCE : 0.5~3.5kg.
 - LIFE TEST: 5,000 CYCLES MIN.
 - TO CONFORM TO SINGATRON HAZARDOUS SUBSTANCE FREE SPEC.
 - OTHER GENERAL SPEC, PLEASE REFER TO "ZDC-G213-Q70F SPEC."
 - HALOGEN FREE PRODUCT IDENTIFICATION MARK ON JACK:
 - HALOGEN FREE PRODUCT IDENTIFICATION LABEL ON PACKAGING:
 - FOR WAVE SOLDERING LEAD-FREE PROCESS.
 - PRINTED DATE CODE "YYMDDXX" ON TOP OF CONNECTOR.

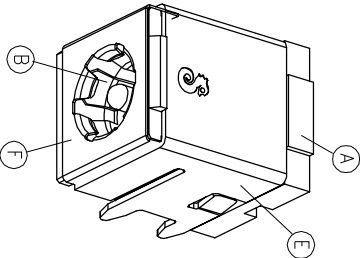
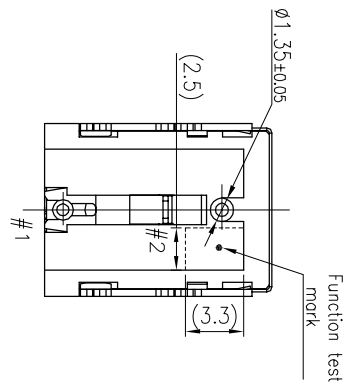
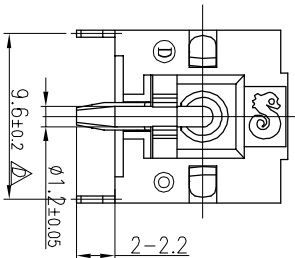
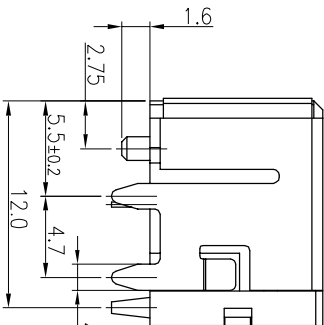
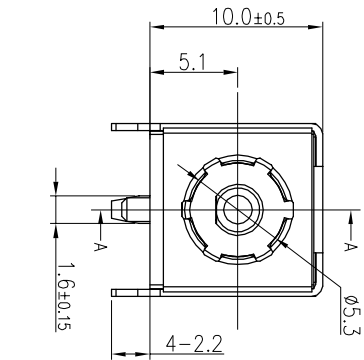
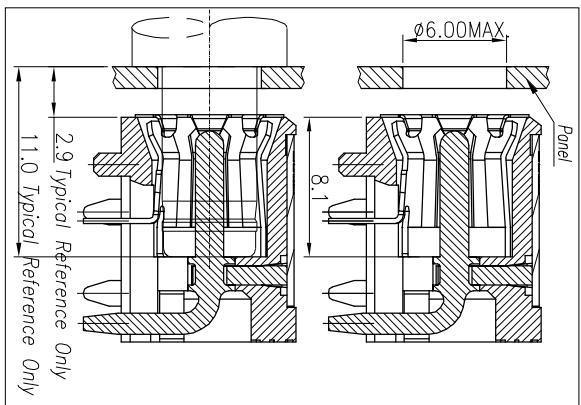
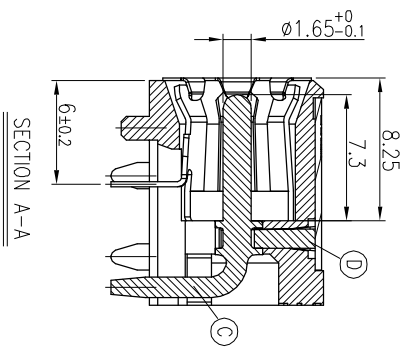
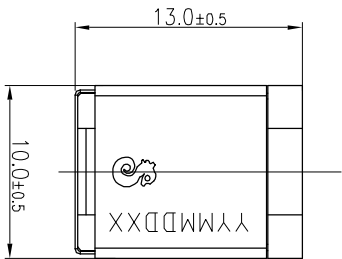
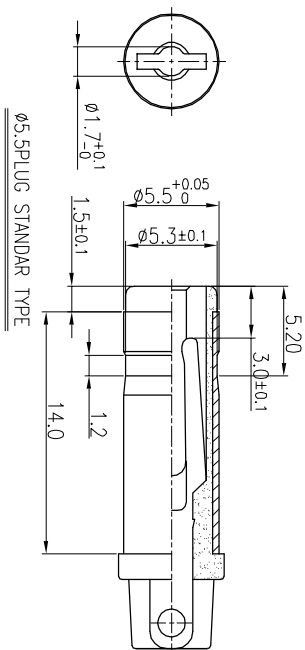
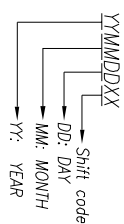
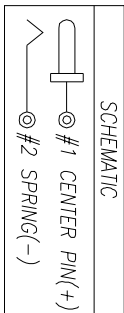

REV.	ECN NO. OR DESCRIPTION	REVISED	DATE
C	ECN NO.:S180838-C	Qizhen	2018.8.21
D	ECN NO.:S180904-C	Qizhen	2018.9.3

NO	DESCRIPTION	QTY	MATERIAL	PLATING & COLOR
F	GROUND	1	STAINLESS STEEL 0.15T	N/A
E	SHELL	1	SPCC 0.4T	Ni 60u" Min OVER Cu 80u" Min.
D	STOPPER	1	HIGH TEMP.THERMOPLASTIC UL94V-0	BLACK
C	CENTER PIN	1	BRASS	4q 20u" OVER Ni 60u"
B	SPRING	1	PHOSPHOR BRONZE 0.3T	Matte Sn 100u" Min OVER Ni 60u" Min
A	BODY	1	HIGH TEMP.THERMOPLASTIC UL94V-0	BLUE(298C)

DECIMALS:	ANGLES:
X :±0.5	X :±2°
X.X :±0.3	X.X :±1°
X.XX :±0.2	

TITLE	DC POWER JACK
DWN	Qizhen
CHKD	SCALE:4:1
APVD	UNIT: mm
	SIZE: A3
	SHEET: 1 OF 2
	REV: D

Singatron Enterprise Co., Ltd.
信晉企業股份有限公司

CUSTOMER COPY

For ECS only

1. GROUNDING CONTACT FIRST

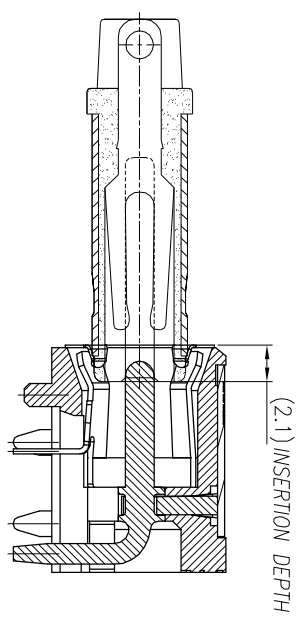

2. NEGATIVE CONTACT

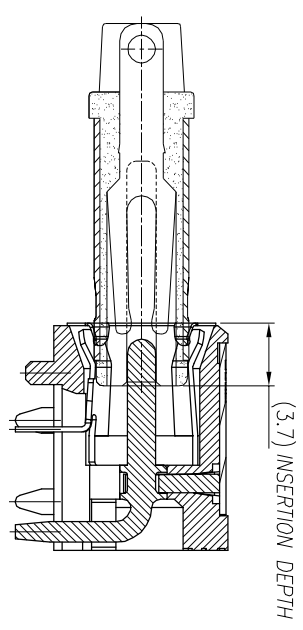

3. POSITIVE CONTACT

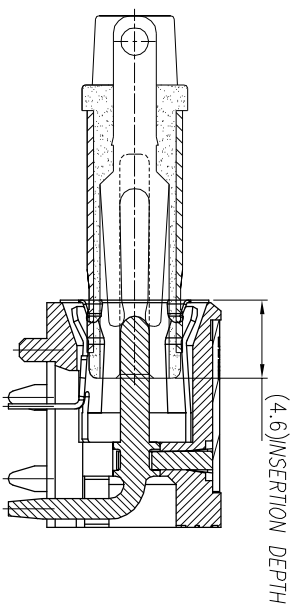

4. FULL INSERTION

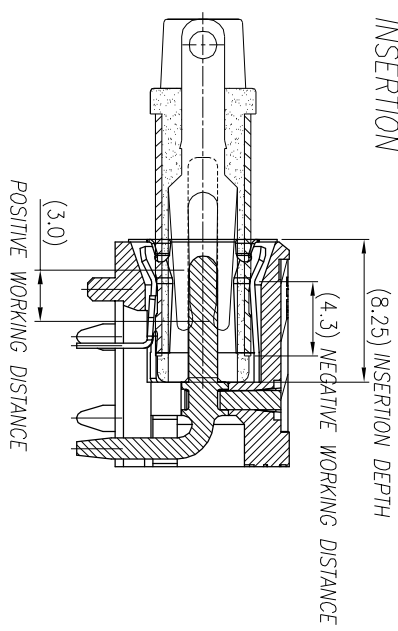

REV:	ECN NO OR DESCRIPTION	REVISED	DATE
C	ECN NO:S180838-C	Qizhen	2018.8.21
D	ECN NO:S180904-C	Qizhen	2018.9.3

NO	DESCRIPTION	QTY	MATERIAL	PLATING & COLOR
UNLESS OTHERWISE SPECIFIED TOLERANCES				
DECIMALS:	ANGLES:			
X :±0.5	X :±2°			
X.X :±0.3	X.X :±1°			
X.XX :±0.2				
TITLE	DC POWER JACK			
DWN	Qizhen	PART NO.	2DC-G213-Q70F	
CHKD		SCALE:4:1	UNIT:	mm
APVD		SIZE: A3	SHEET:2 OF 2	REV:D

CUSTOMER COPY

Singatron Enterprise Co., Ltd.
信晉企業股份有限公司