

REV.	ECN NO OR DESCRIPTION	REVISED	DATE
A	PDR NO.S221118-2A	JIE-FU	2023.04.20

SPECIFICATIONS:

- ELECTRICAL CHARACTERISTICS:
 - RATING: 20V 10A.
 - CONTACT RESISTANCE: 30mΩ MAX.
 - DIELECTRIC WITHSTANDING VOLTAGE: 500V AC FOR ONE MINUTE.
 - INSULATION RESISTANCE: 100MΩ MIN. MEASURED BY 500 VDC
- MECHANICAL CHARACTERISTICS:
 - INSERTION FORCE : 3.5 kg Max.
 - WITHDRAWAL FORCE : 0.5~3.5kg.
- LIFE TEST: 5,000 CYCLES MIN.
- TO CONFORM TO SINGATRON HAZARDOUS SUBSTANCE FREE SPEC.
- PRINTED DATE CODE "YYMMDD" ON TOP OF CONNECTOR.
 - DD: DAY
 - MM: MONTH
 - YY: YEAR
- HALOGEN FREE PRODUCT IDENTIFICATION MARK ON JACK:
- HALOGEN FREE PRODUCT IDENTIFICATION LABEL ON PACKAGING:
- FOR WAVE SOLDERING LEAD-FREE PROCESS.
- THE PANEL'S ID MUST BE GREATER THAN THE PLUG'S OD WHICH MUST HAVE A DIFFERENCE OF LESS THAN OR EQUAL TO 0.5 mm.(AS SHOWN IN FIGURE 1.)

DD: DAY
MM: MONTH
YY: YEAR

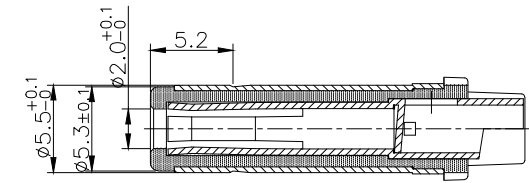

MATING PLUG
(TOLERANCE: ±0.05)

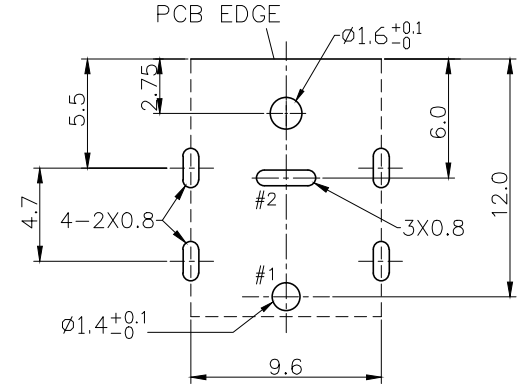
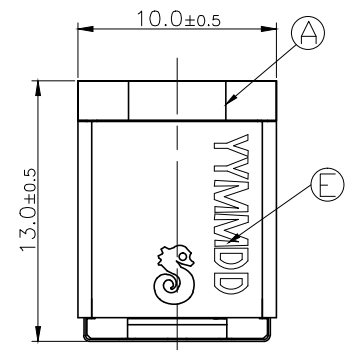

RECOMMEND P.C.B LAYOUT
TOP VIEW(TOLERANCE ±0.05)

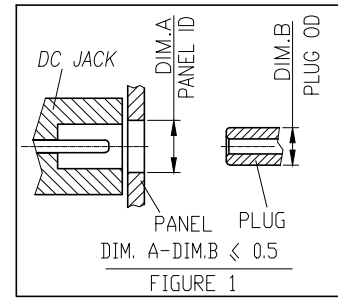
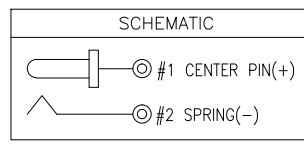
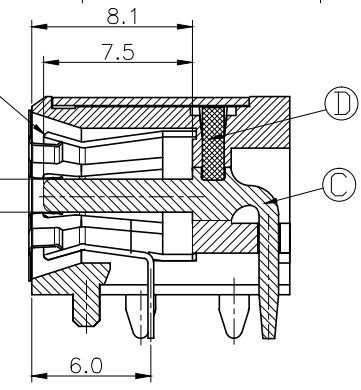
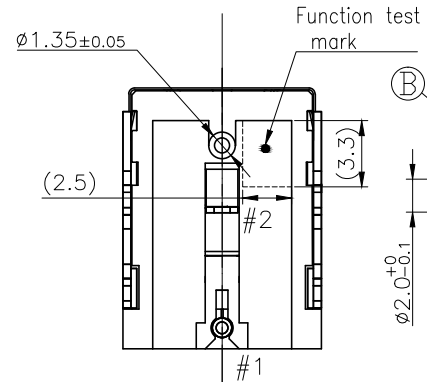
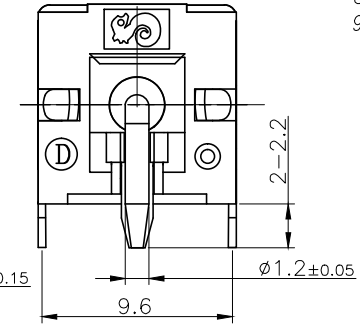
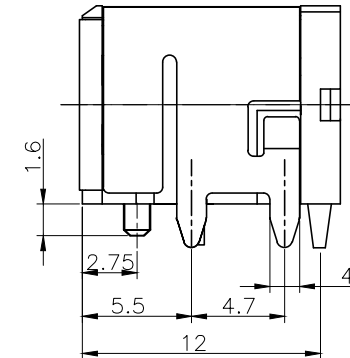
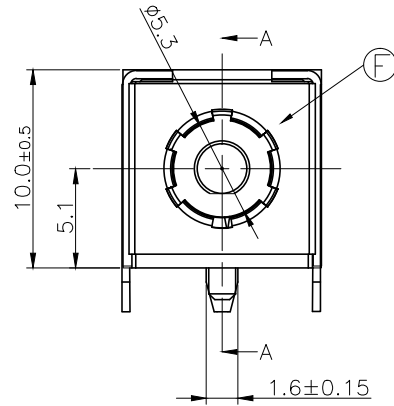

F	GROUND	1	STAINLESS STEEL 0.15T	N/A
E	SHELL	1	SPCC 0.4T	Ni 60u" Min,Cu 80u" Min
D	STOPPER	1	HIGH TEMP.THERMOPLASTIC UL94V-0	BLACK
C	PIN	1	BRASS	GOLD FLASH
B	SPRING	1	PHOSPHOR BRONZE 0.3T	OVER Ni 60u" Min.
A	BODY	1	HIGH TEMP.THERMOPLASTIC UL94V-0	BLACK
NO	DESCRIPTION	QTY	MATERIAL	PLATING & COLOR

UNLESS OTHERWISE SPECIFIED TOLERANCES		Singatron Enterprise Co., Ltd. 信音企業股份有限公司	
DECIMALS:	ANGLES:	TITLE	
X :±0.5	X :±2°	DC POWER JACK	
X.X :±0.3	X.X :±1°	DWN	JIE-FU PART NO. 2DC-G213B400F
X.XX :±0.2		CHKD	LUSSEN SCALE:4:1 UNIT: mm
		APVD	LIAO SIZE: A3 SHEET:1 OF 1 REV:A
CUSTOMER COPY			