

REV.	ECN NO OR DESCRIPTION	REVISED	DATE
A	PDR No: T070830-3A	ZP-CHEN	2008.01.10
B	ECN NO.S081005	Boye	2008.11.24

SPECIFICATIONS:

- 1.INSERTION FORCE: 3.0KG Max
- 2.INSULATION RESISTANCE BETWEEN ANY ADJACENT TERMINALS SHALL NOT BE LESS THAN 100 MEGOHMS BY 500 VOLTS MEGGER.
- 3.JACK SHALL WITHSTAND 250 VOLTS BETWEEN ANY ADJACENT TERMINAL FOR ONE MINUTE.
- 4.CONTACT RESISTANCE SHALL NOT EXCEED 30mΩ.
- 5.JACK SHALL WITHSTAND 5,000 CYCLES OF INSERTION AND WITHDRAWAL WITH TESTING PLUG,AND CONTACT RESISTANCE SHALL NOT EXCEED 50mΩ.
- 6.MEASURING CONDITION:
TEMPERATURE: FROM 5°C TO 35°C.
RELATIVE HUMIDITY: FROM 40% TO 85%.
- 7.ENVIRONMENTAL SPECIFICATIONS:
7.1 HUMIDITY TEST: HUMIDITY 90% TO 95% TEMPERATURE 40°C ±2°C FOR 96 HOURS.
7.2 HEAT TEST: TEMPERATURE 70°C ± 2°C (HUMIDITY BELOW 50%) FOR 96 HOURS.
7.3 COLD TEST: TEMPERATURE -40°C ± 2°C FOR 96 HOURS.
- 8.TO CONFORM TO SINGATRON HAZARDOUS SUBSTANCE FREE SPEC.
- 9.GREEN PRODUCT IDENTIFICATION MARK ON JACK: 
- 10.GREEN PRODUCT IDENTIFICATION LABEL ON PACKAGING: GP PASS
- 11.FOR LEAD FREE PROCESS.

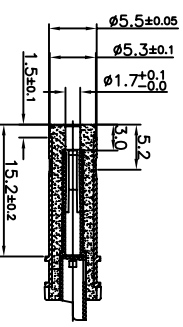
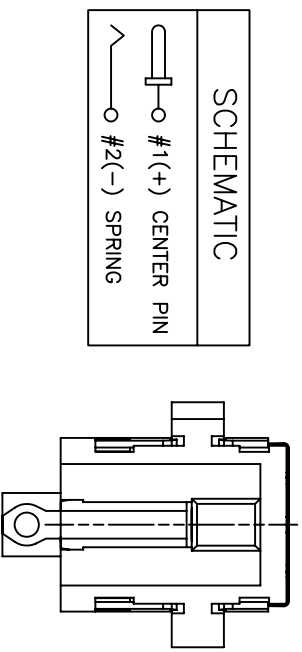
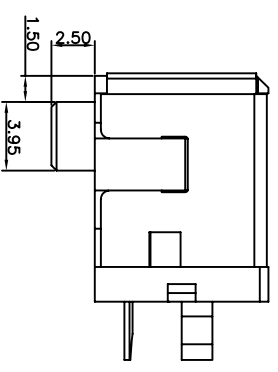
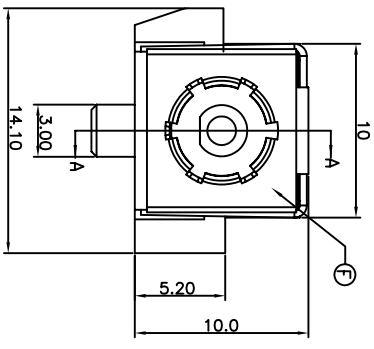
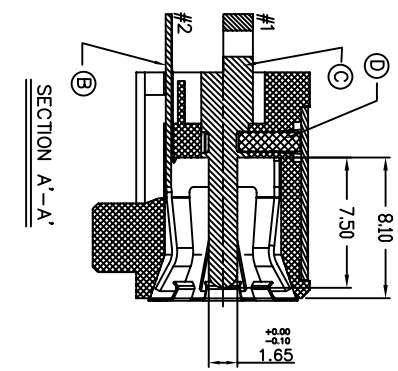
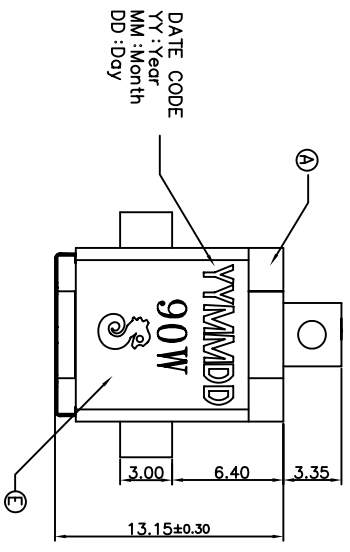

F	GROUND	1	STAINLESS STEEL 0.15t	N/A
E	SHIELDING	1	SPCC-SD 0.4t	Ni 60u" Over Cu80u"
D	STOPPER	1	THERMOPLASTIC UL94V-0	BLACK
C	PIN	1	BRASS BAR	Ag 20u" Over Ni 50u"
B	SPRING	1	COPPER ALLOY 0.3t	Sn 60u" Over Ni 60u"
A	BODY	1	THERMOPLASTIC UL94V-0	BLUE COLOR (PANTONE NO.298C)
NO	DESCRIPTION	QTY	MATERIAL	PLATING & COLOR

UNLESS OTHERWISE SPECIFIED TOLERANCES

 Singatron Enterprise Co., Ltd.
信音企業股份有限公司

DECIMALS:	ANGLES:	TITLE	DC POWER JACK
X : ±0.5	X : ±2°	DWN	Boye 2008.11.24
X.X : ±0.3	X.X : ±1'	CHKD	Over-2mm 2008.11.28
X.XX : ±0.2		APVD	Mov

CUSTOMER COPY