

REV.	ECN NO OR DESCRIPTION	REVISED	DATE
C	ECN:C140130 MODIFY PLATING	CAOCHEN	2014.07.01
D	ECN:C140250 MODIFY DRAWING	CAOCHEN	2014.11.25
E	ECN:C150093 MODIFY DRAWING	CAOCHEN	2015.09.14
F	ECN:S170135-Q	YUREN	2017.4.25

SPECIFICATIONS:

- RATING: DC 20V 10A
- INSERTION FORCE: 2.5Kg MAX.
WITHDRAWAL FORCE: 1.0Kg~2.5Kg
- INSULATION RESISTANCE BETWEEN ANY ADJACENT TERMINALS SHALL NOT BE LESS THAN 100 MEGOHMS BY 500 VOLTS MEGGER.
- JACK SHALL WITHSTAND 250 VOLTS BETWEEN ANY ADJACENT TERMINAL FOR ONE MINUTE.
- CONTACT RESISTANCE (INITIAL) SHALL NOT EXCEED 30mΩ
CONTACT RESISTANCE (AFTER LIFE TEST) SHALL NOT EXCEED 30mΩ
ABOVE MUST USE 2DP-G313-B01 PLUG
- MEASURING CONDITION:
TEMPERATURE: FROM 5°C TO 35°C.
RELATIVE HUMIDITY: FROM 40% TO 85%.
- ENVIRONMENTAL SPECIFICATIONS:
 - HUMIDITY TEST: HUMIDITY 90% TO 95% TEMPERATURE 40°C ± 2°C FOR 96 HOURS.
 - HEAT TEST: TEMPERATURE 70°C ± 2°C (HUMIDITY BELOW 50%) FOR 96 HOURS.
 - COLD TEST: TEMPERATURE -40°C ± 2°C FOR 96 HOURS.
- MATING PLUG : SINGATRON'S P/N : 2DP-G313-B01(PLUG SET)
- TO CONFORM TO SINGATRON HAZARDOUS SUBSTANCE FREE SPEC.
- HALOGEN FREE PRODUCT IDENTIFICATION MARK ON PRODUCT:
- HALOGEN FREE PRODUCT IDENTIFICATION LABEL ON PACKAGING:
- PACKING: TAPE & REEL
- FOR REFLOW SOLDERING LEAD-FREE PROCESS.

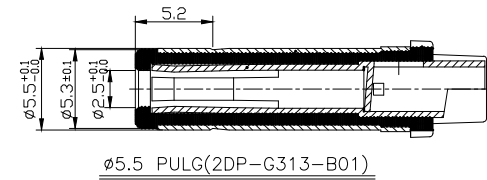

F	GROUNDING	1	STAINLESS STEEL 0.1t	
E	SHIELD	1	SPCC-SD 0.4t	Solderable Ni
D	TERMINAL	1	STAINLESS STEEL 0.3t	
C	PIN	1	BRASS BAR	G/F
B	TIP	1	COPPER ALLOY 0.3t	TIN PLATING
A	BODY	1	HIGH TEMPTHERMAL PLASTIC UL 94V-0	BLACK COLOR
NO	DESCRIPTION	QTY	MATERIAL	PLATING & COLOR
UNLESS OTHERWISE SPECIFIED TOLERANCES		Singatron Enterprise Co., Ltd. 信音企業股份有限公司		
DECIMALS:		TITLE		
X	:±0.5	DC JACK		
X.X	:±0.3	DWN YUREN PART NO. 2DC-G313-B07		
X.XX	:±0.2	CHKD	CERRY	SCALE 1:1 UNIT: mm
		APVD	LIAO	SIZE: A3 SHEET: 10F1 REV: F
CUSTOMER COPY				

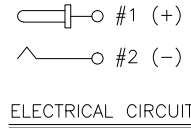

A - A SECTION

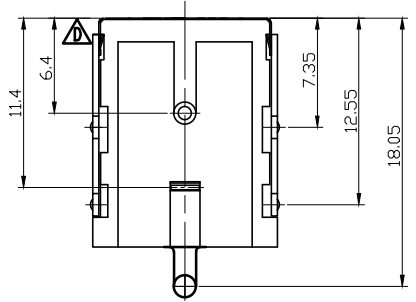
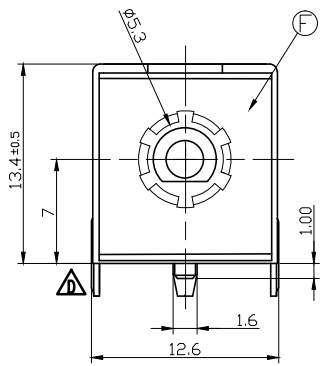
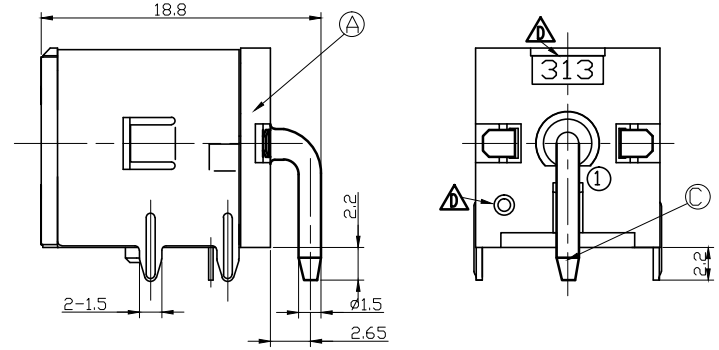
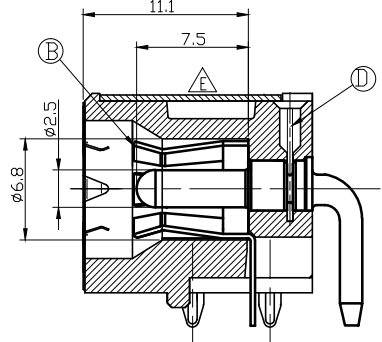

RECOMMENDED P.C.B LAYOUT
SOLDERING SIDE

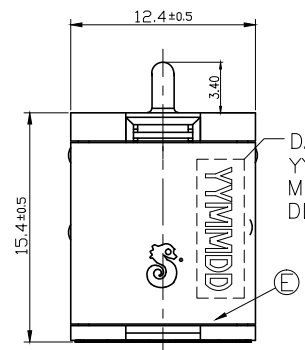
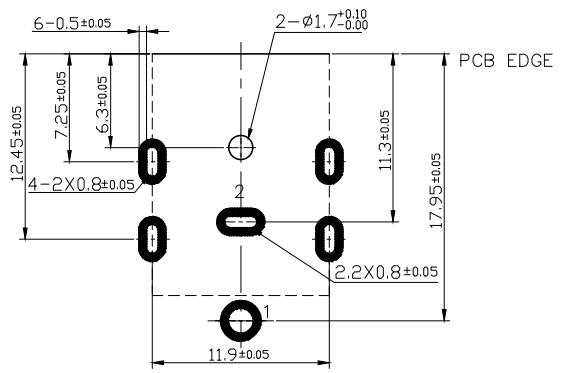

DATE CODE
YY: Year (04)
MM: Month (01~12)
DD: Day (01~31)