

REV.	ECN NO. OR DESCRIPTION	REVISED	DATE
A	PDR NO.T11221-2A	QAING	2012.02.17

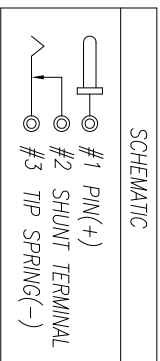

- SPECIFICATIONS:**
- ELECTRICAL CHARACTERISTICS:**
 - RATING: 20V 7A
 - CONTACT RESISTANCE: 30mOHMS MAX.(INITIAL)
 - DIELECTRIC WITHSTANDING VOLTAGE: 250V AC FOR ONE MINUTE.
 - INSULATION RESISTANCE: 100MEGOHMS MIN. MEASURED BY 500 VDC
 - MECHANICAL CHARACTERISTICS:**
 - INSERTION FORCE : 0.4KG-3.5KG
 - WITHDRAWAL FORCE : 0.4KG-3.5KG
 - LIFE TEST: 5,000 CYCLES MIN.
 - OTHER GENERAL SPEC. TO REFER "ZDCXXXX SERIES SPEC."
 - TO CONFORM TO SINGATRON HAZARDOUS SUBSTANCE FREE SPEC.
 - HALOGEN FREE PRODUCT IDENTIFICATION MARK ON PRODUCT: (H)
 - HALOGEN FREE PRODUCT IDENTIFICATION LOGO ON PACKAGING: (H)
 - FOR REFLOW SOLDERING LEAD-FREE PROCESS.

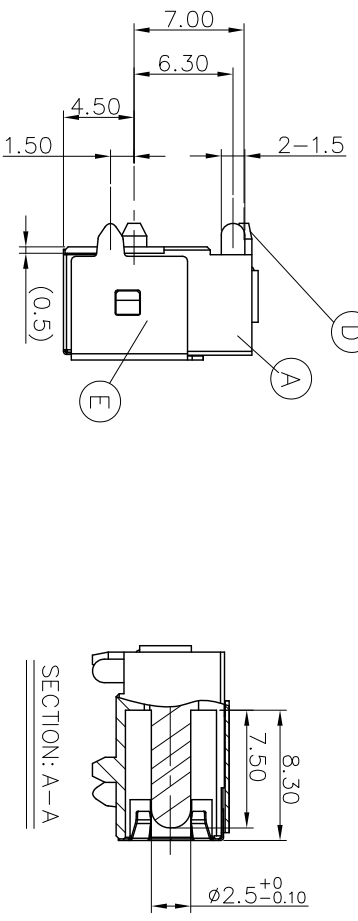
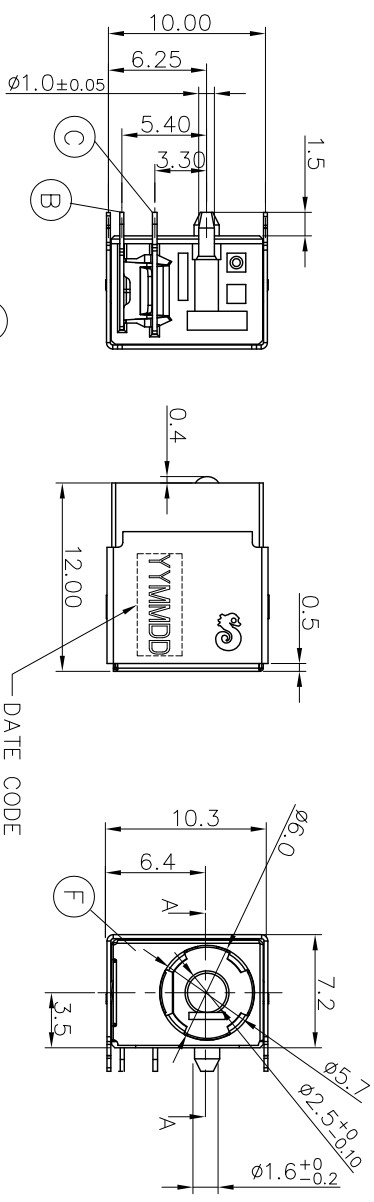
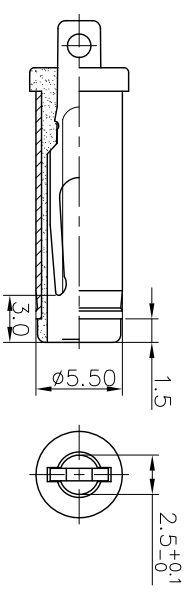
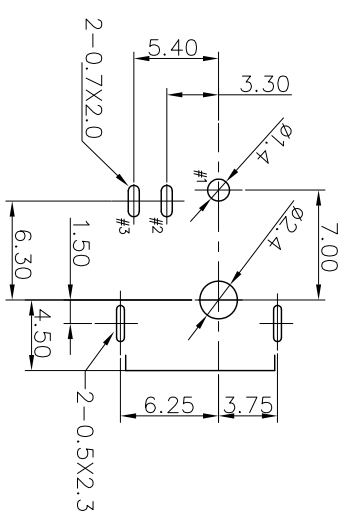

- GROUNDING
- SHIELDING
- PIN
- SHUNT TERMINAL
- TIP SPRING
- BODY

F	GROUNDING	1	STAINLESS 0.1T	N/A
E	SHIELDING	1	BRASS STRIP 0.25T	Ni 60u" Min
D	PIN	1	BRASS BAR	GOLD FLASH OVER Ni 50U"
C	SHUNT TERMINAL	1	BRASS STRIP 0.3T	GOLD FLASH OVER Ni 50U"
B	TIP SPRING	1	BRASS STRIP 0.25T	Ag 20U" OVER Ni 50U"
A	BODY	1	HIGH TEMP. THERMOPLASTIC UL 94V-0	BLACK
NO	DESCRIPTION	QTY	MATERIAL	PLATING & COLOR
UNLESS OTHERWISE SPECIFIED TOLERANCES				
Singatron Enterprise Co., Ltd. 信管企業股份有限公司				
TITLE		DC POWER JACK		
DWN	DATE: 2012.02.17	PART NO.	2DC-G756-BC1P	
CHKD	REV: 2012.02.17	SCALE: 1:1	UNIT: mm	
APVD	ISSER: 2012.02.17	SIZE: A3	SHEET: 1 OF 1	REV: A
CUSTOMER COPY				