

REV.	ECN NO OR DESCRIPTION	REVISED	DATE
A	PRODUCT RELEASE	BERYL	2005.5.11
B	ECN NO.:T070336	Angela	2007.11.20
C	ECN NO.:S130113	SEAN	2013.04.18
D	ECN NO.:S141150	Ken	2015.1.28
E	ECN NO.:S150317-Q	YUREN	2015.05.22

SPECIFICATIONS:

- RATING: DC 20V 5A (24V 5A).
- INSERTION FORCE: 0.4KG-3.0KG  
WITHDRAWAL FORCE: 0.4KG-3.0KG
- INSULATION RESISTANCE BETWEEN ANY ADJACENT TERMINALS SHALL NOT BE LESS THAN 100 MEGOHMS BY 500 VOLTS MEGGER.
- JACK SHALL WITHSTAND 250 VOLTS BETWEEN ANY ADJACENT TERMINAL FOR ONE MINUTE.
- CONTACT RESISTANCE SHALL NOT EXCEED  $30m\Omega$ .
- JACK SHALL WITHSTAND 5,000 CYCLES OF INSERTION AND WITHDRAWAL WITH TESTING PLUG, AND CONTACT RESISTANCE SHALL NOT EXCEED  $100m\Omega$ .
- MEASURING CONDITION:  
TEMPERATURE: FROM 5°C TO 35°C.  
RELATIVE HUMIDITY: FROM 40% TO 85%
- ENVIRONMENTAL SPECIFICATIONS:
  - HUMIDITY TEST: HUMIDITY 90% TO 95% TEMPERATURE 40°C ± 2°C FOR 96 HOURS.
  - HEAT TEST: TEMPERATURE 70°C ± 2°C (HUMIDITY BELOW 50%) FOR 96 HOURS.
  - COLD TEST: TEMPERATURE -40°C ± 2°C FOR 96 HOURS.
- SOLDERABILITY TEST: THE TERMINATION IS AT LEAST 95% COVERED BY A CONTINUOUS NEW SOLDER COATING.  
TEST CONDITION: DIP IN MOLTEN SOLDER FOR 5 Sec. AT 245±5°C (TERMINATION SHALL BE IMMERSED IN FLUX BEFORE TEST)
- TO CONFORM TO THE "SE-01-001" & "ROHS DIRECTIVE"
- GREEN PRODUCT IDENTIFICATION MARK IN JACK:
- GREEN PRODUCT IDENTIFICATION LABEL IN PACKING: **G.P. PASS**
- FOR LEAD-FREE PROCESS.
- PACKING: TAPE & REEL

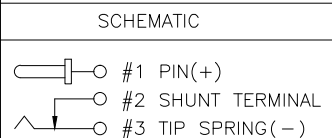
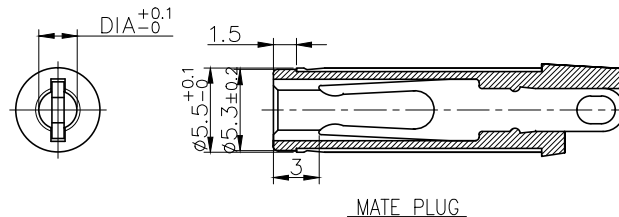
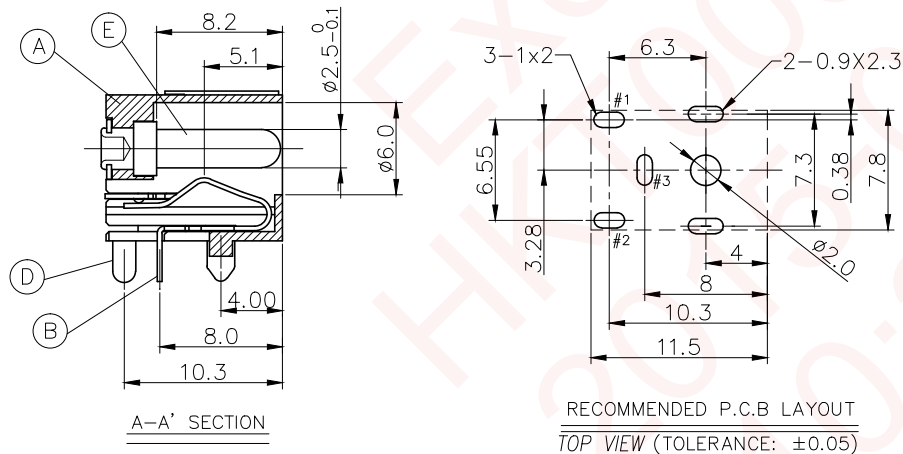
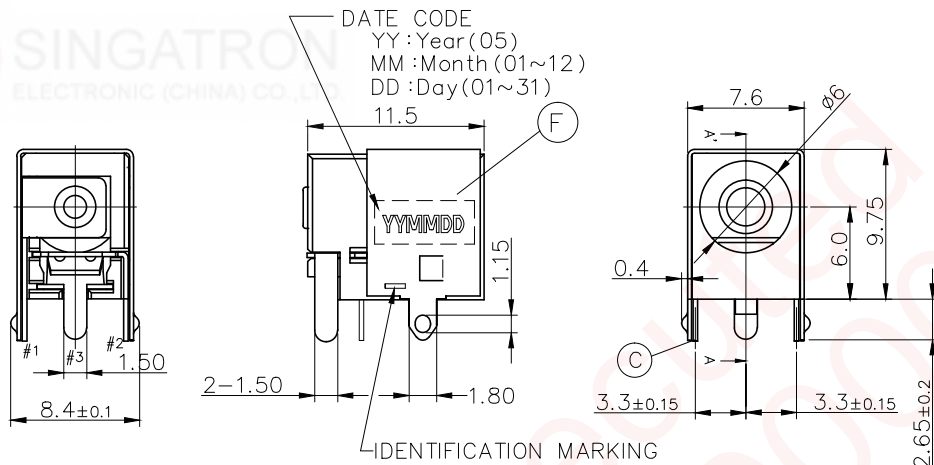

F	SHIELDING	1	BRASS STRIP 0.25t	可焊NI
E	PIN	1	BRASS BAR	NICKEL PLATING
D	TERMINAL	1	BRASS STRIP 0.3t	SILVER PLATING
C	SHUNT TERMINAL	1	BRASS STRIP 0.3t	SILVER PLATING
B	TIP SPRING	1	COPPER ALLOY 0.3t	SILVER PLATING
A	BODY	1	HIGH TEMP. THERMOPLASTIC UL 94V-0	BLACK COLOR
NO	DESCRIPTION	QTY	MATERIAL	PLATING & COLOR
UNLESS OTHERWISE SPECIFIED TOLERANCES			Singatron Enterprise Co., Ltd. 信音企業股份有限公司	
DECIMALS:		TITLE		
X	:±0.5	DC POWER JACK		
X.X	:±0.3	DWN YUREN PART NO. 2DC-S006-B15		
X.XX	:±0.2	CHKD	Cerry	SCALE 3:1 UNIT: mm
		APVD	Liao	SIZE: A3 SHEET: 1 OF 1 REV: E
CUSTOMER COPY				