

REV.	ECN NO.	OR DESCRIPTION	REVISED	DATE
D	ECN NO. S090318		Samming	2009.04.30
E	ECN NO. S100731		Swina	2010.07.30
F	ECN NO. S120751		SEAN	2013.01.14

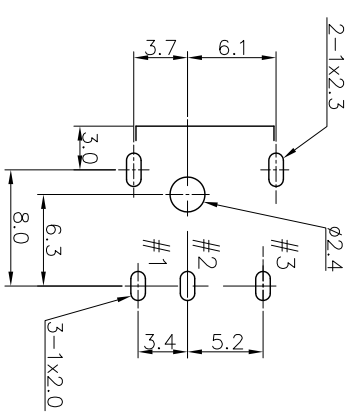

Recommended PCB(1.2mm) Layout
 <TOP VIEW>TOLERANCE:±0.05

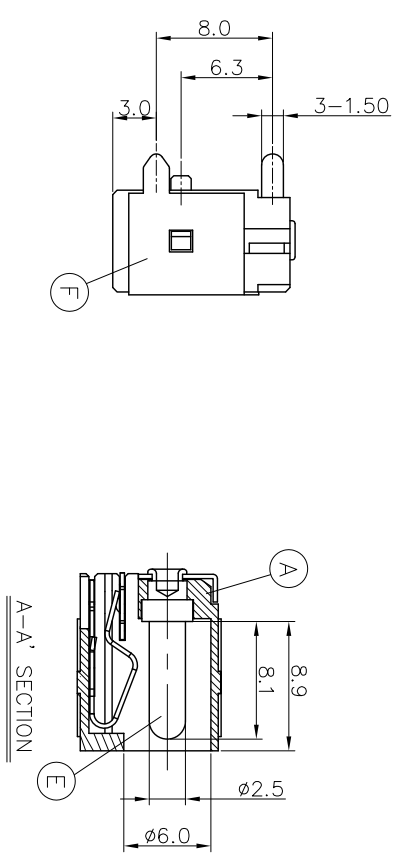
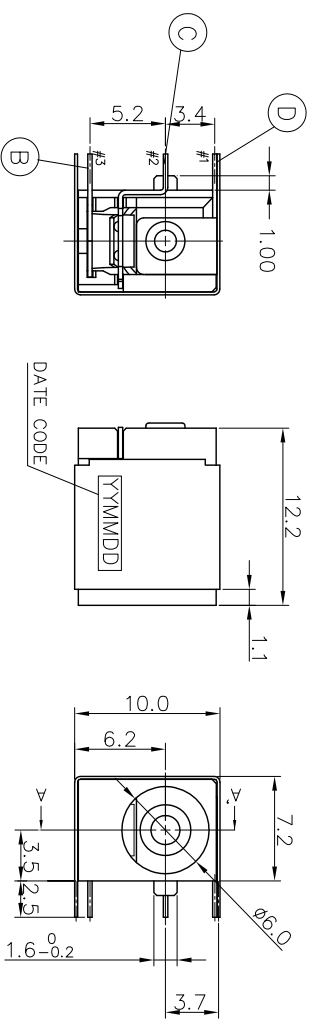
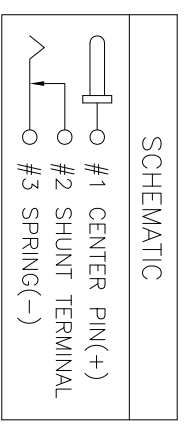

P/N:2DP-5525-AH2
 MATING PLUG(REF ONLY)

1. RATING: DC 20V 4A
 2. LOAD SIDE CAPACITANCE: 4.7μF*4 MIN.
 3. INSERTION FORCE: 0.4KG-3.0KG
 4. WITHDRAWAL FORCE: 0.4KG-3.0KG
 5. INSULATION RESISTANCE BETWEEN ANY ADJACENT TERMINALS SHALL NOT BE LESS THAN 100 MΩ BY 500 VOLTS MEGGER.
 6. JACK SHALL WITHSTAND 250 VOLTS BETWEEN ANY ADJACENT TERMINAL FOR ONE MINUTE.
 7. CONTACT RESISTANCE SHALL NOT EXCEED 30 mΩ.
 8. JACK SHALL WITHSTAND 5,000 CYCLES OF INSERTION AND WITHDRAWAL WITH TESTING PLUG, AND CONTACT RESISTANCE SHALL NOT EXCEED 100mΩ MEASURING CONDITION.
 9. TEMPERATURE: FROM 5°C TO 35°C.
 10. RELATIVE HUMIDITY: FROM 40% TO 85%
 11. ENVIRONMENTAL SPECIFICATIONS:
 9.1 HUMIDITY TEST: HUMIDITY 90% TO 95% TEMPERATURE 40°C ± 2°C FOR 96 HOURS.
 9.2 HEAT TEST: TEMPERATURE 70°C ± 2°C (HUMIDITY BELOW 50%) FOR 96 HOURS.
 9.3 COLD TEST: TEMPERATURE -40°C ± 2°C FOR 96 HOURS.
 10. SOLDERABILITY TEST: THE TERMINATION IS AT LEAST 95% COVERED BY A CONTINUOUS NEW SOLDER COATING.
 TEST CONDITION: DIP IN MOLTEN SOLDER FOR 5 Sec. AT 245±5°C (TERMINATION SHALL BE IMMERSED IN FLUX BEFORE TEST)
 11. TO CONFORM TO SINGATRON HAZARDOUS SUBSTANCE FREE SPECIFICATION.
 12. GREEN PRODUCT IDENTIFICATION MARK ON JACK: **G.P. PASS**
 13. GREEN PRODUCT IDENTIFICATION LABEL ON PACKAGING: **G.P. PASS**
 14. FOR LEAD-FREE PROCESS.
 15. DATE CODE DESCRIPTION:
 YY MM DD
 DAY MONTH YEAR

NO	DESCRIPTION	QTY	MATERIAL	PLATING&COLOR
F	SHIELDING	1	BRASS STRIP 0.2t	Ni60u"MIN.
E	PIN	1	BRASS BAR	Ni 60u"MIN
D	TERMINAL	1	BRASS STRIP 0.3t	Ni60u"MIN.
C	SHUNT TERMINAL	1	BRASS STRIP 0.3t	Ag 20u"MIN
B	TIP SPRING A	1	YCUTM-H 0.3T	Ag 20u" Over N20u"
A	BODY	1	HIGH TEMP. THERMOPLASTIC UL 94V-0	BLACK COLOR

UNLESS OTHERWISE SPECIFIED TOLERANCES		ANGLES:		SINGATRON ENTERPRISE CO., LTD.	
X	:±0.5	X	:±2°	信普企業股份有限公司 Singatron Enterprise Co., Ltd.	
X.X	:±0.3	X.X	:±1°		
X.XX	:±0.2				
TITLE		DC POWER JACK		SHEET: 1 OF 1	
DWN	SEAN	PART NO.	2DC-S026-B15	UNIT: mm	REV: F
CHKD	TOM	SCALE: N/A			
APVD	QUAN	SIZE: A3			

CUSTOMER COPY