

- SPECIFICATIONS:
- ELECTRICAL CHARACTERISTICS:
 - 1-1 RATING: DC 42V 10A OR AC 30V 10A
 - 1-2 CONTACT RESISTANCE: 30mΩ MAX. (INITIAL)
 - 1-3 DIELECTRIC WITHSTANDING VOLTAGE: 250V AC FOR ONE MINUTE
 - 1-4 INSULATION RESISTANCE: 100MΩ MIN. MEASURED BY 500 VDC
 - MECHANICAL CHARACTERISTICS:
 - 2-1 INSERTION FORCE: 3.0 KG Max.
 - 2-2 WITHDRAWAL FORCE: 0.3 KG Min.
 - LIFE TEST: 5,000 CYCLES MIN.
 - TO CONFORM TO SINGATRON HAZARDOUS SUBSTANCE FREE SPEC.
 - HALOGEN FREE PRODUCT IDENTIFICATION MARK ON JACK:
 - HALOGEN FREE PRODUCT IDENTIFICATION LABEL ON PACKAGING:
 - FOR REFLOW SOLDERING LEAD-FREE PROCESS.
 - THE PANEL'S ID MUST BE GREATER THAN THE PLUG'S OD WHICH MUST HAVE A DIFFERENCE OF LESS THAN OR EQUAL TO 0.5 mm. (AS SHOWN IN FIGURE 1)
 - PRINTED DATE CODE "YYMMDD" ON TOP OF CONNECTOR.

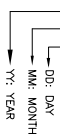
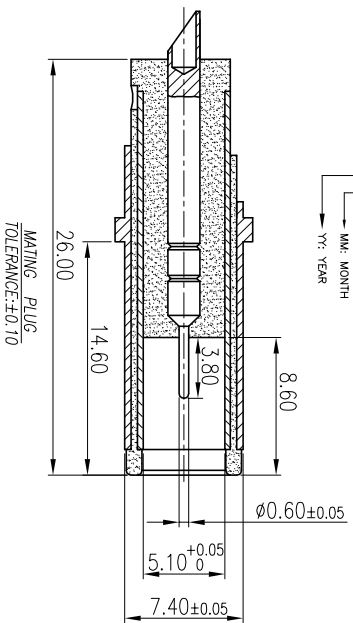

F	SHELL	1	BRASS, 0.35T	Ni 60u"
E	SIGNAL	1	COPPER ALLOY, 0.30T	Au 1u" Min. ON CONTACT AREA; Matte Sn 100u" ON SOLDER TAIL; ALL OVER Ni 60u"
D	SPRING(-)	1	COPPER ALLOY, 0.30T	Au 1u" Min. ON CONTACT AREA; Matte Sn 100u" ON SOLDER TAIL; ALL OVER Ni 60u"
C	SPRING(+)	1	COPPER ALLOY, 0.30T	Au 1u" Min. ON CONTACT AREA; Matte Sn 100u" ON SOLDER TAIL; ALL OVER Ni 60u"
B	COVER	1	HIGH THERMOPLASTIC TEMP. UL 94V-0	BLACK
A	BODY	1	HIGH THERMOPLASTIC TEMP. UL 94V-0	BLACK
NO	DESCRIPTION	QTY	MATERIAL	PLATING & COLOR
UNLESS OTHERWISE SPECIFIED TOLERANCES				
Singatron Enterprise Co., Ltd. 信登企業股份有限公司				
DECIMALS:		ANGLES:		
X	:±0.5	X	:±2°	
XX	:±0.3	X.X	:±1°	
XXX	:±0.2			
TITLE		DC JACK		
DMW	Smile	PART NO.	2DC-S060-027F	
CHKD	Sky	SCALE:	4:1 UNIT: mm	
APVD	Lussen	SIZE:	A3 SHEET: 1 OF 1 REV: A	
CUSTOMER COPY				

REV.	EGN NO OR DESCRIPTION	REVISED	DATE
A	PDR NO: T140519-1A	Smile	2014.07.30