

REV.	ECN NO OR DESCRIPTION	REVISED	DATE
A	PDR NO:T150709-2A	Jun	2015.12.24
B	ECN NO:T190308-C	KEN	2019.08.28

SPECIFICATIONS:

- ELECTRICAL CHARACTERISTICS:
 - RATING: DC 42V 10A OR AC 30V 10A.
 - CONTACT RESISTANCE: 30mΩ MAX.(INITIAL)
 - DIELECTRIC WITHSTANDING VOLTAGE: 250V AC FOR ONE MINUTE
 - INSULATION RESISTANCE: 100MΩ MIN. MEASURED BY 500 VDC
- MECHANICAL CHARACTERISTICS:
 - INSERTION FORCE :3.0 KG Max.
 - WITHDRAWAL FORCE : 0.3 KG Min.
- LIFE TEST: 5,000 CYCLES MIN.
- TO CONFORM TO SINGATRON HAZARDOUS SUBSTANCE FREE SPEC.
- HALOGEN FREE PRODUCT IDENTIFICATION MARK ON JACK:
- HALOGEN FREE PRODUCT IDENTIFICATION LABEL ON PACKAGING:
- FOR REFLOW SOLDERING LEAD-FREE PROCESS.
- PRINTED DATE CODE "YYMMDD" ON TOP OF CONNECTOR.
 - DD: DAY
 - MM: MONTH
 - YY: YEAR
- OPERATING TEMPERATURE: -40~+85°C
- RESISTANCE TO SOLDER HEAT: 270°C MAX., 5SEC
- MINIMUM-OF-50-GRAMS-NORMAL-FORCE

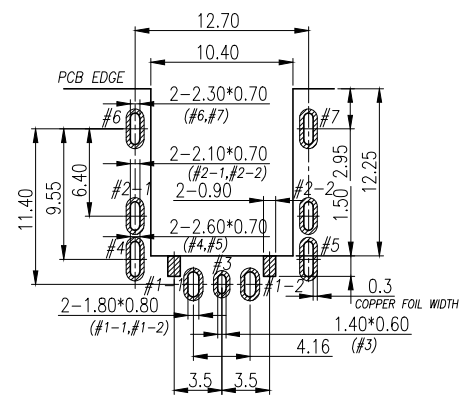
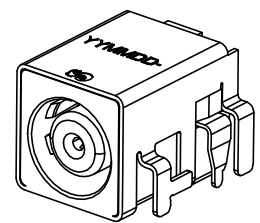
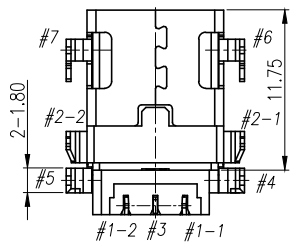
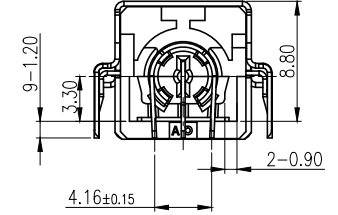
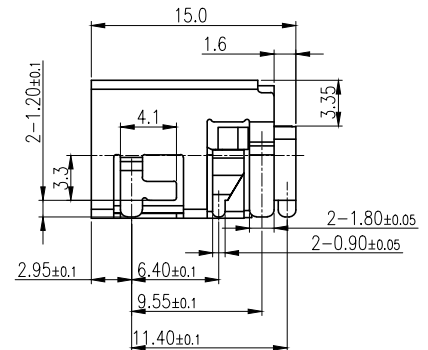
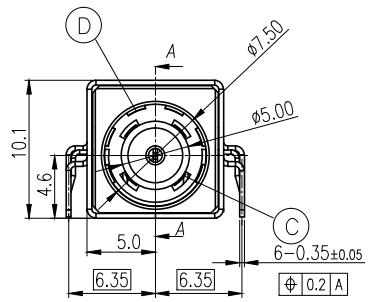
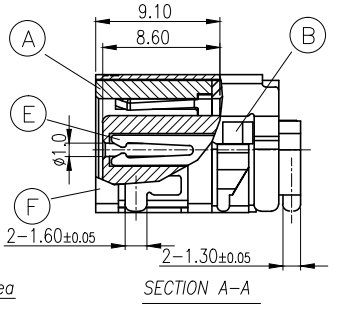
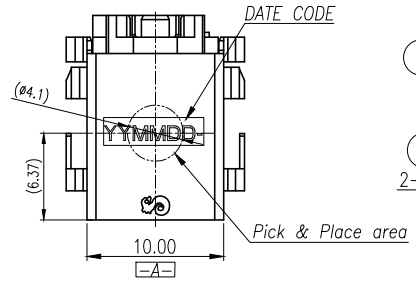
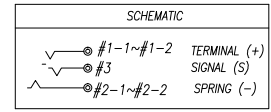
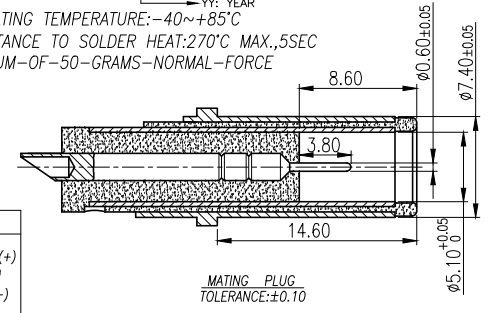
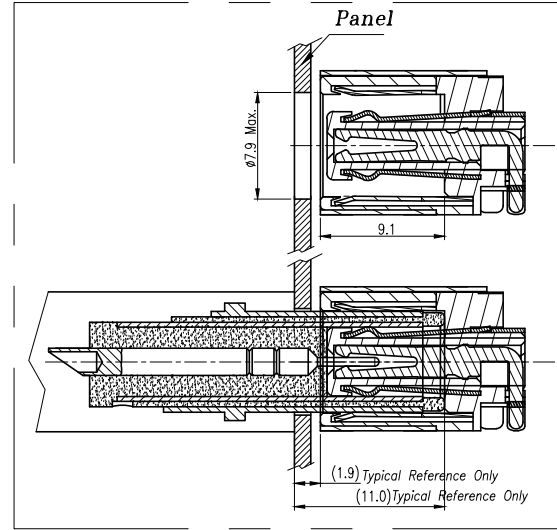

F	SHELL	1	C2680 0.35T	Ni 60u"
E	SIGNAL	1	C5191 0.30T	Au 15u" ON CONTACT AREA; Matt Sn 100u" ON SOLDER TAIL; ALL OVER Ni 70u"min
D	SPRING(-)	1	C5210 0.30T	Au 15u" ON CONTACT AREA; Matt Sn 100u" ON SOLDER TAIL; ALL OVER Ni 70u"min
C	SPRING(+)	1	C5210 0.30T	Au 15u" ON CONTACT AREA; Matt Sn 100u" ON SOLDER TAIL; ALL OVER Ni 70u"min
B	COVER	1	LCP UL 94V-0	BLACK
A	BODY	1	LCP UL 94V-0	BLACK
NO	DESCRIPTION	QTY	MATERIAL	PLATING & COLOR

UNLESS OTHERWISE SPECIFIED TOLERANCES		Singatron Enterprise Co., Ltd. 信音企業股份有限公司	
DECIMALS:	ANGLES:	TITLE DC POWER JACK	
X :±0.5	X :±2°	DWN	KEN PART NO.2DC-S060-029F
X.X :±0.3	X.X :±1°	CHKD	SKY SCALE:4:1 UNIT: mm
X.XX :±0.2		APVD	LUSSEN SIZE: A3 SHEET:1 OF 2 REV: B
CUSTOMER COPY			

REV.	ECN NO OR DESCRIPTION	REVISED	DATE
A	PDR NO:T150709-2A	Jun	2015.12.24
B	ECN NO:T190308-C	KEN	2019.08.28

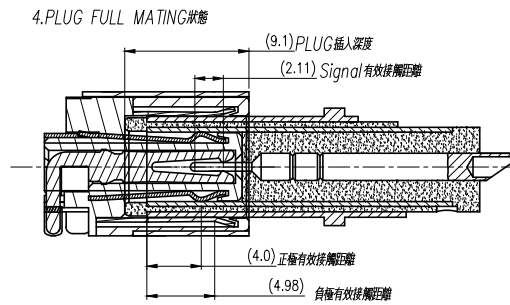
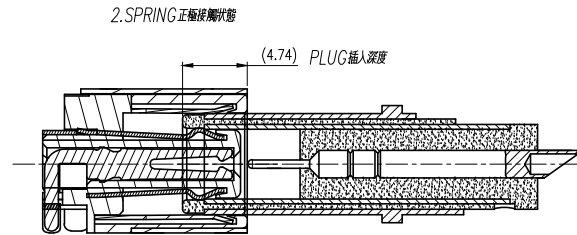
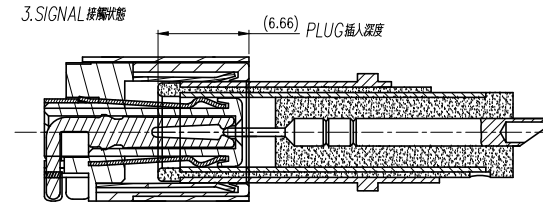
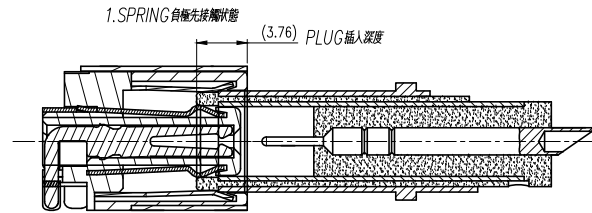

NO	DESCRIPTION	QTY	MATERIAL	PLATING & COLOR
UNLESS OTHERWISE SPECIFIED TOLERANCES		Singatron Enterprise Co., Ltd. 信音企業股份有限公司		
DECIMALS:	ANGLES:	TITLE	MATING DRAWING	
X : ±0.5	X : ±2°	DWN KEN	PART NO. 2DC-S060-029F	
X.X : ±0.3	X.X : ±1°	CHKD SKY	SCALE 4:1	UNIT: mm
X.XX : ±0.2		APVD LUSSEN	SIZE: A3	SHEET: 2 OF 2
CUSTOMER COPY				
				REV: B