

REV.	ECN NO OR DESCRIPTION	REVISED	DATE
C	ECN:C130097-5 UPDATE DRAWING	ZJK	2013.05.20
D	ECN:C150051 MODIFY DRAWING	CAOCHEN	2015.05.19
E	ECN:C150093 MODIFY DRAWING	CAOCHEN	2015.09.14
F	ECN NO:S160101-R	YUREN	2016.06.28

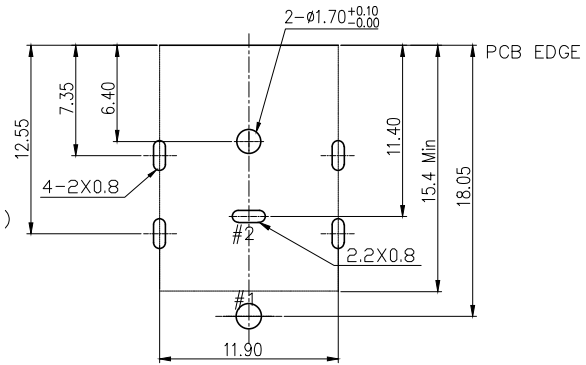

- SPECIFICATIONS:
- RATING: DC 20V 10A
 - INSERTION FORCE: 0.5Kg~2.5Kg
WITHDRAWAL FORCE: 1.0Kg~2.5Kg
 - INSULATION RESISTANCE BETWEEN ANY ADJACENT TERMINALS SHALL NOT BE LESS THAN 100 MEGOHMS BY 500 VOLTS MEGGER.
 - JACK SHALL WITHSTAND 250 VOLTS BETWEEN ANY ADJACENT TERMINAL FOR ONE MINUTE.
 - CONTACT RESISTANCE SHALL NOT EXCEED 30mΩ
 - JACK SHALL WITHSTAND 5,000 CYCLES OF INSERTION AND WITHDRAWAL WITH TESTING PLUG, AND CONTACT RESISTANCE SHALL NOT EXCEED 30mΩ
 - MEASURING CONDITION:
TEMPERATURE: FROM 5°C TO 35°C.
RELATIVE HUMIDITY: FROM 40% TO 85%.
 - ENVIRONMENTAL SPECIFICATIONS:
 - HUMIDITY TEST: HUMIDITY 90% TO 95% TEMPERATURE 40°C ±2°C FOR 96 HOURS.
 - HEAT TEST: TEMPERATURE 70°C ± 2°C (HUMIDITY BELOW 50%) FOR 96 HOURS.
 - COLD TEST: TEMPERATURE -40°C ± 2°C FOR 96 HOURS.
 - MATING PLUG : SINGATRON'S P/N : 2DP-S113-L01 (PLUG SET)
 - PACKING: TAPE & REEL
 - TO CONFORM TO THE "SE-01-001" & "ROHS DIRECTIVE"
 - HALOGEN FREE PRODUCT IDENTIFICATION MARK ON PRODUCT:
 - HALOGEN FREE PRODUCT IDENTIFICATION LABEL ON PACKAGING:
 - FOR REFLOW SOLDERING LEAD-FREE PROCESS.
 - SOLDER ABILITY AND MAX. SOLDER TEMPERATURE ACCORDING ICP /JEDEC J-STD-020C.

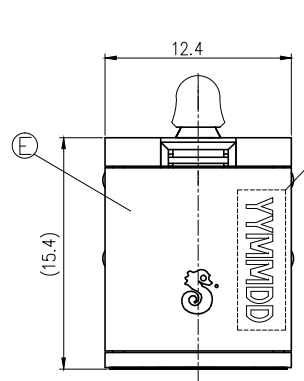
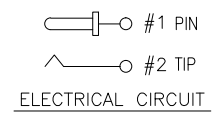
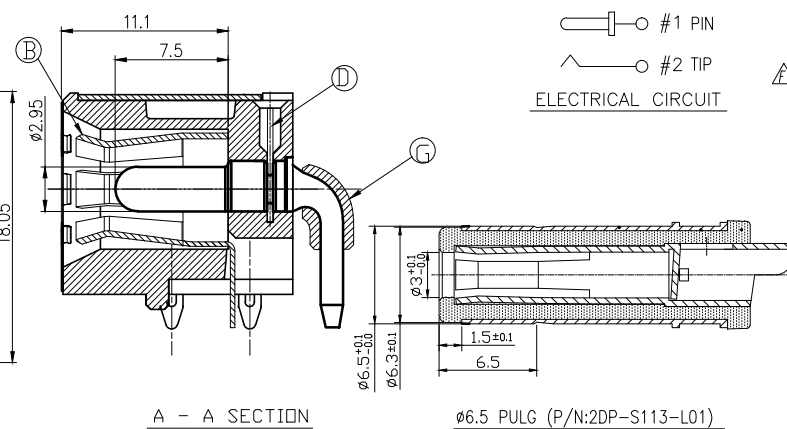
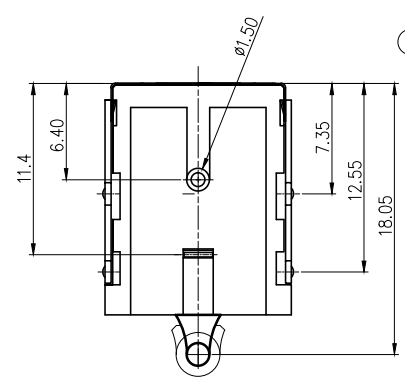
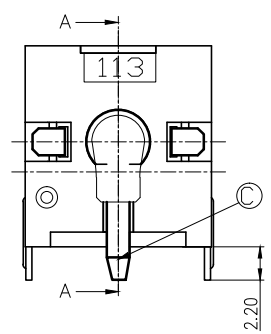
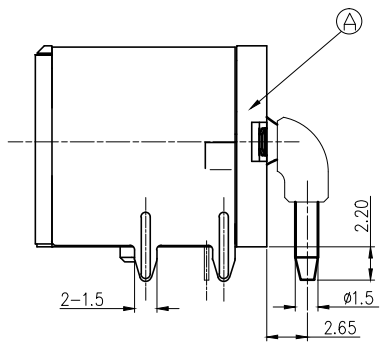
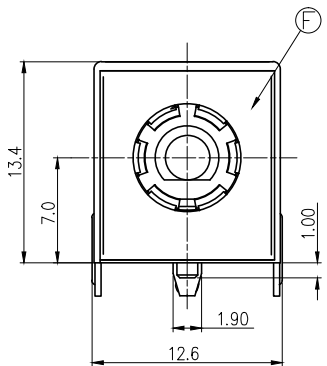

NO	DESCRIPTION	QTY	MATERIAL	PLATING & COLOR
G	HEAT SHRINKABLE TUBE	1	POLYOLEFIN 3.2φ	BLACK
F	GROUNDING	1	STAINLESS STEEL 0.1t	
E	SHIELDING	1	SPCC-SD 0.4t	可焊NI
D	TERMINAL	1	STAINLESS STEEL 0.3t	
C	PIN	1	BRASS BAR	SILVER PLATING
B	TIP	1	COPPER ALLOY 0.3t	TIN PLATING
A	BODY	1	HIGH TEMP.THERMOPLASTIC UL 94V-0	BLACK

UNLESS OTHERWISE SPECIFIED TOLERANCES		Singatron Enterprise Co., Ltd. 信音企業股份有限公司	
DECIMALS:	ANGLES:	TITLE DC POWER JACK	
X :±0.5	X :±2°	DWN	YUREN PART NO. 2DC-S113-L05
X.X :±0.3	X.X :±1°	CHKD	CERRY SCALE:3/1 UNIT: mm
X.XX :±0.2		APVD	LIAO SIZE: A3 SHEET:1 OF 1 REV:F
CUSTOMER COPY			