

| REV. | ECN NO OR DESCRIPTION | REVISED | DATE |
|------|--------------------------------|---------|------------|
| A | PRODUCT RELEASE | ALLEN | 2011.03.23 |
| B | ECN:C150051 MODIFY DRAWING | CAOCHEN | 2015.05.18 |
| C | ECN:C150093 MODIFY DRAWING | CAOCHEN | 2015.09.14 |
| D | ECN NO:S160101-R | YUREN | 2016.06.30 |
| E | ECN NO:S202010-E02 \triangle | KEN | 2020.12.18 |

- SPECIFICATIONS:**
- 1.RATING: DC 20V 10A
 - 2.INSERTION FORCE: 0.5Kg~2.5Kg
WITHDRAWAL FORCE: 1.0Kg~2.5Kg
 - 3.INSULATION RESISTANCE BETWEEN ANY ADJACENT TERMINALS SHALL NOT BE LESS THAN 100 MEGOHMS BY 500 VOLTS MEGGER.
 - 4.JACK SHALL WITHSTAND 250 VOLTS BETWEEN ANY ADJACENT TERMINAL FOR ONE MINUTE.
 - 5.CONTACT RESISTANCE SHALL NOT EXCEED 30m Ω
 - 6.JACK SHALL WITHSTAND 5,000 CYCLES OF INSERTION AND WITHDRAWAL WITH TESTING PLUG,AND CONTACT RESISTANCE SHALL NOT EXCEED 30m Ω
 - 7.MEASURING CONDITION:
TEMPERATURE: FROM 5°C TO 35°C.
RELATIVE HUMIDITY: FROM 40% TO 85%.
 - 8.ENVIRONMENTAL SPECIFICATIONS:
8.1 HUMIDITY TEST: HUMIDITY 90% TO 95% TEMPERATURE 40°C \pm 2°C FOR 96 HOURS.
8.2 HEAT TEST: TEMPERATURE 70°C \pm 2°C (HUMIDITY BELOW 50%) FOR 96 HOURS.
8.3 COLD TEST: TEMPERATURE -40°C \pm 2°C FOR 96 HOURS.
 - 9.MATING PLUG : SINGATRON'S P/N : 2DP-S113-L01(PLUG SET)
 - 10.PACKING: TAPE & REEL
 - 11.TO CONFORM TO THE "SE-01-001" & "ROHS DIRECTIVE"
 - 12.HALOGEN FREE PRODUCT IDENTIFICATION MARK ON PRODUCT:
 - 13.HALOGEN FREE PRODUCT IDENTIFICATION LABEL ON PACKAGING:
 - 14.FOR REFLOW SOLDERING LEAD-FREE PROCESS.
 - 15.SOLDER ABILITY AND MAX. SOLDER TEMPERATURE ACCORDING ICP /JEDEC J-STD-020C.

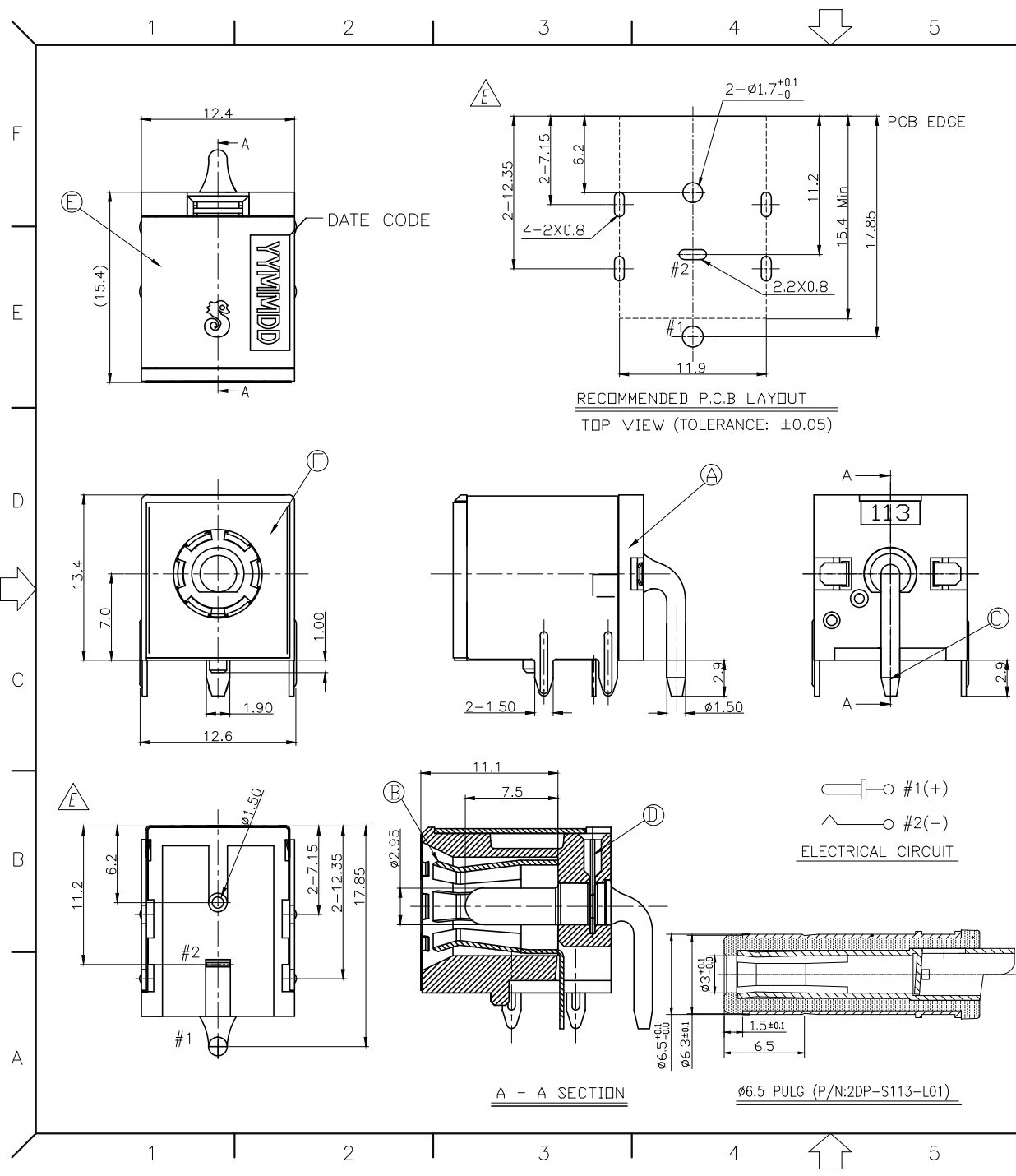

| NO | DESCRIPTION | QTY | MATERIAL | PLATING & COLOR |
|----|-------------|-----|----------------------------------|-----------------|
| F | GROUNDING | 1 | STAINLESS STEEL 0.1t | |
| E | SHIELDING | 1 | SPCC-SD 0.4t | 可焊NI |
| D | TERMINAL | 1 | STAINLESS STEEL 0.3t | |
| C | PIN | 1 | BRASS BAR | SILVER PLATING |
| B | TIP | 1 | COPPER ALLOY 0.3t | TIN PLATING |
| A | BODY | 1 | HIGH TEMP.THERMOPLASTIC UL 94V-0 | BLACK |

| UNLESS OTHERWISE SPECIFIED TOLERANCES | SINGATRON ENTERPRISE CO., LTD. 信音企業股份有限公司 | | |
|---------------------------------------|--|--------------------------------|--------------|
| DECIMALS: | TITLE: DC POWER JACK | | |
| X : ± 0.5 | ANGLES: | DWN ken PART NO. 2DC-S113-R12F | |
| X.X : ± 0.3 | X : $\pm 2^\circ$ | CHKD lussen SCALE:3/1 | UNIT: mm |
| X.XX : ± 0.2 | X.X : $\pm 1^\circ$ | APVD liao SIZE: A3 | SHEET:1 OF 1 |
| | | REV:E | |
| | | CUSTOMER COPY | |