

REV.	ECN NO. OR DESCRIPTION	REVISED	DATE
A	PRODUCT PDR RELEASE	Fan Luo	2010.11.9
D	ECN NO: S160101-R	YUREN	2016.06.30
E	ECN NO: S190708-C	Sugur	2019.10.21

**SPECIFICATIONS:**

1. RATING: DC 20V 9A
2. INSERTION FORCE: 2.5kgf Max  
WITHDRAWAL FORCE: 1.0~2.5kgf
3. INSULATION RESISTANCE: 100M MIN. MEASURED BY 500 VDC
4. JACK SHALL WITHSTAND 500 VOLTS BETWEEN ANY ADJACENT TERMINAL FOR ONE MINUTE.
5. CONTACT RESISTANCE SHALL NOT EXCEED 30mΩ.
6. OTHER GENERAL SPEC. TO REFER "2DC-S228-B17F SPEC".
7. LIFE TEST: 5,000 CYCLES MIN.
8. PRINTED DATE CODE "YMMDD" ON TOP OF CONNECTOR.
9. TO CONFORM TO SINGATRON HAZARDOUS SUBSTANCE FREE SPEC.
10. HALOGEN FREE PRODUCT IDENTIFICATION MARK ON PRODUCT.
11. HALOGEN FREE PRODUCT IDENTIFICATION LABEL ON PACKAGING.
12. TO CONFORM TO SINGATRON HAZARDOUS SUBSTANCE FREE SPEC.
13. FOR REFLOW SOLDERING LEAD-FREE PROCESS.
14. PACKAGING: TAPE&REEL

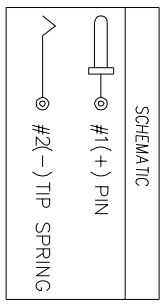
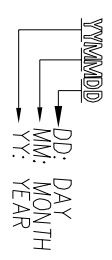
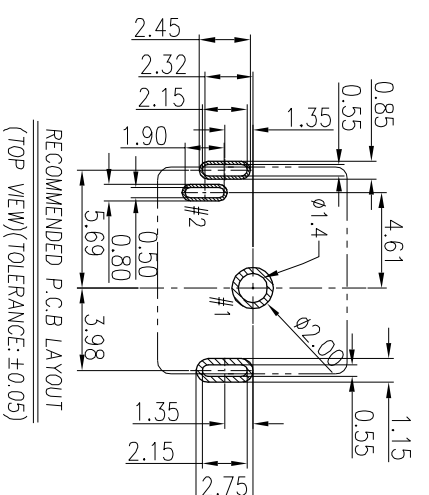
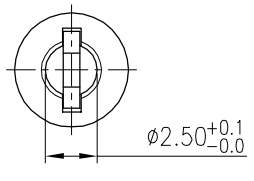
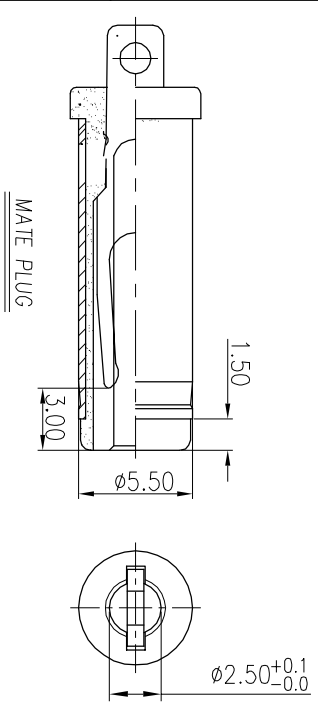
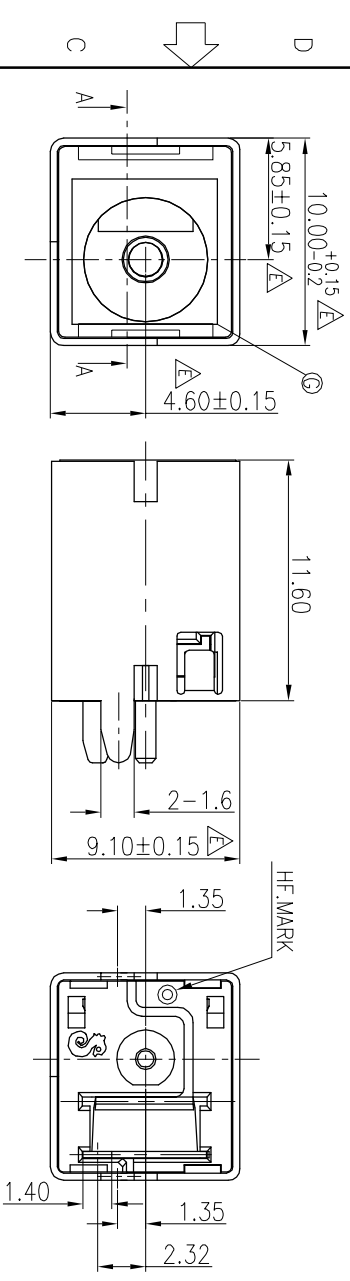
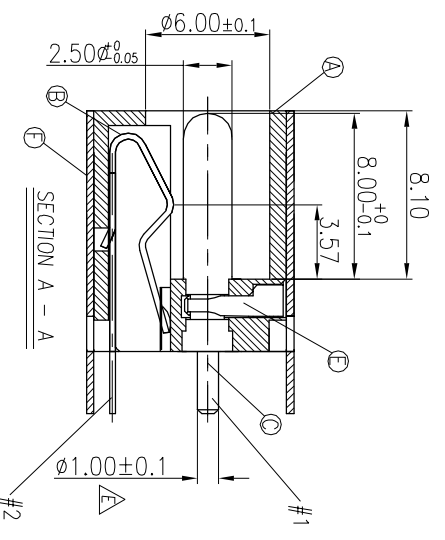
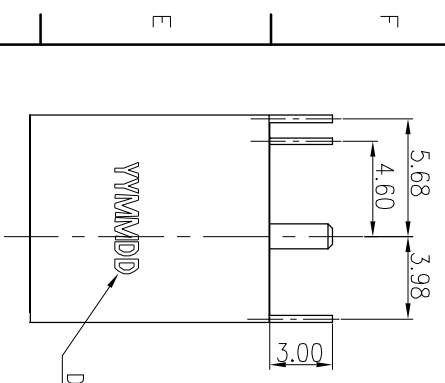

C	MYLAR	1	MYLAR 0.075t	TRANSPARENT
F	SHIELD	1	COOPER ALLOY 0.35t	BLACK
E	TERMINAL	1	HIGHT TEMP THERMOPLASTIC UHQ4-0	BLACK
C	CENTER PIN	1	BRASS BAR	GOLD FLASH
B	TIP SPRING	1	COOPER ALLOY 0.3t	PLATED SILVER
A	BODY	1	HIGHT TEMP THERMOPLASTIC UHQ4-0	BLACK
NO	DESCRIPTION	QTY	MATERIAL	PLATING & COLOR

UNLESS OTHERWISE SPECIFIED TOLERANCES

Singatron Enterprise Co., Ltd.  
信晉企業股份有限公司

TITLE	SHELL
DWN	Sugur
CHKD	Spring
APVD	Lussen

DECIMALS: ANGLES:

±0.5 X ±2°  
±0.3 X.X ±1°  
±0.2 X.XX

PART NO. 2DC-S228-B17F  
SCALE 1:1 UNIT: mm  
SIZE: A3 SHEET: 10F1  
REV: E

CUSTOMER COPY