

REV.	ECN NO OR DESCRIPTION	REVISED	DATE
A	PRODUCE SRELEASE	Fanluo	2011.03.21

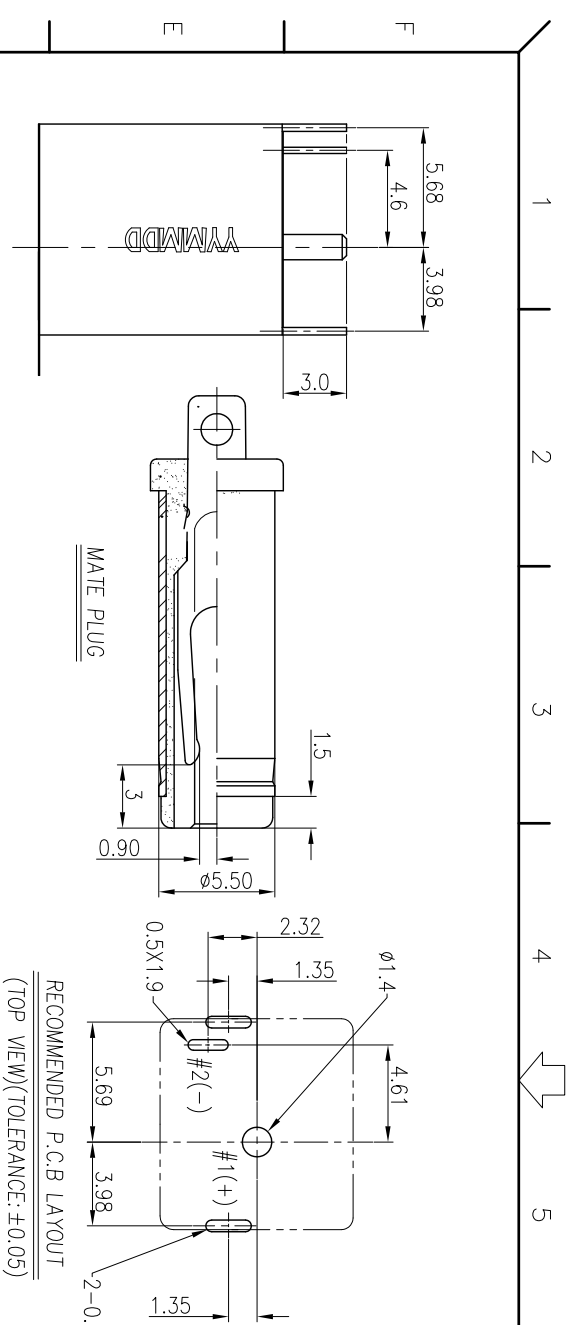

RECOMMENDED P.C.B LAYOUT
(TOP VIEW)(TOLERANCE: ±0.05)

2-0.55X2.15

4 JACK SHALL WITHSTAND 500 VOLTS BETWEEN ANY ADJACENT TERMINAL FOR ONE MINUTE.

5 CONTACT RESISTANCE SHALL NOT EXCEED 30mΩ

6 JACK SHALL WITHSTAND 5,000 CYCLES OF INSERTION AND WITHDRAWAL WITH TESTING PLUG, AND CONTACT RESISTANCE SHALL NOT EXCEED 60mΩ

7 MEASURING CONDITION:
TEMPERATURE: FROM 5°C TO 35°C
RELATIVE HUMIDITY: FROM 40% TO 85%

8 PRINTED DATE CODE "YMMDD" ON TOP OF CONNECTOR.

9 TO CONFORM TO SINGATRON HAZARDOUS SUBSTANCE FREE SPEC.

10 HALOGEN FREE PRODUCT IDENTIFICATION MARK ON JACK: ☉

11 HALOGEN FREE PRODUCT IDENTIFICATION LABEL ON PACKAGING: 12.FOR 260°C. 10SEC. WAVE SOLDERING LEAD-FREE PROCESS.

13 PACKAGING: TAPE&REEL

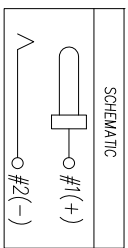

- SPECIFICATIONS:
- RATING: 20V 7A
 - INSERTION FORCE: 1.5kgf Max
WITHDRAWAL FORCE: 1.5kgf Min(INITIAL)
WITHDRAWAL FORCE: 1.0kgf~2.5kgf(FINAL)
 - INSULATION RESISTANCE BETWEEN ANY ADJACENT TERMINALS SHALL NOT BE LESS THAN 100 MEGOHMS BY 500V DC.
 - JACK SHALL WITHSTAND 500 VOLTS BETWEEN ANY ADJACENT TERMINAL FOR ONE MINUTE.
 - CONTACT RESISTANCE SHALL NOT EXCEED 30mΩ
 - JACK SHALL WITHSTAND 5,000 CYCLES OF INSERTION AND WITHDRAWAL WITH TESTING PLUG, AND CONTACT RESISTANCE SHALL NOT EXCEED 60mΩ
 - MEASURING CONDITION:
TEMPERATURE: FROM 5°C TO 35°C
RELATIVE HUMIDITY: FROM 40% TO 85%
 - PRINTED DATE CODE "YMMDD" ON TOP OF CONNECTOR.
 - TO CONFORM TO SINGATRON HAZARDOUS SUBSTANCE FREE SPEC.
 - HALOGEN FREE PRODUCT IDENTIFICATION MARK ON JACK: ☉
 - HALOGEN FREE PRODUCT IDENTIFICATION LABEL ON PACKAGING: 12.FOR 260°C. 10SEC. WAVE SOLDERING LEAD-FREE PROCESS.
 - PACKAGING: TAPE&REEL

NO	DESCRIPTION	QTY	MATERIAL	PLATING & COLOR
F	WYLAR	1	INSULATION FILM 0.075I	TRANSPARENT
E	SHIELD	1	COOPER ALLOY 0.35T	鍍錫 50~80u" NICKEL MIN
D	TERMINAL	1	HIGHT TEMP THERMOPLASTIC UL94V-0	BLACK COLOR
C	CENTER PIN	1	BRASS BAR	Ag20u" Min, Ni60u" Min.
B	TIP SPRING	1	COOPER ALLOY 0.3T	Ag20u" Min, Ni60u" Min.
A	BODY	1	HIGHT TEMP THERMOPLASTIC UL94V-0	BLACK COLOR

UNLESS OTHERWISE SPECIFIED TOLERANCES

Singatron Enterprise Co., Ltd.
信音企業股份有限公司

DECIMALS:	ANGLES:	TITLE
X : ±0.5	X : ±2°	DC POWER JACK
X.X : ±0.3	X.X : ±1°	
X.XX : ±0.2		

CHKD	SCALE	UNIT	REV
MWKA/2011.03.22	4:1	mm	A
APVD	SIZE: A4	SHEET: 10F1	

PART NO. 2DC-S228-B18F

DC JACK INSERT DEPTH

CUSTOMER COPY