

REV.	ECN NO OR DESCRIPTION	REVISED	DATE
A	PRODUCT RELEASE	CHEN	2015.01.21
B	ECN NO: S160101-R	YUREN	2016.6.30

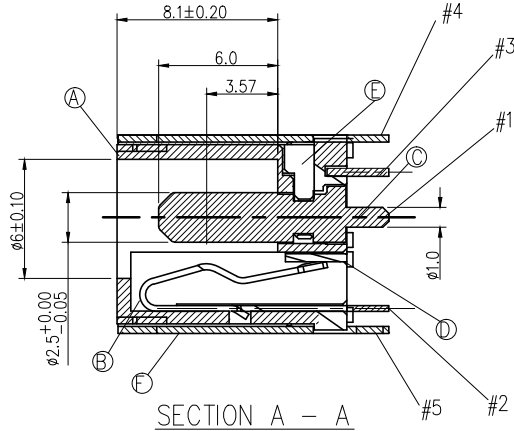
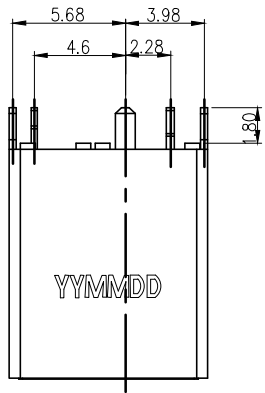

SPECIFICATIONS:

- ELECTRICAL CHARACTERISTICS:
 - RATING: 20V 5.5A
 - CONTACT RESISTANCE: 30mΩ MAX.(INITIAL)
 - DIELECTRIC WITHSTANDING VOLTAGE: 500V AC FOR ONE MINUTE
 - INSULATION RESISTANCE: 100MΩ MIN. MEASURED BY 500 VDC
- MECHANICAL CHARACTERISTICS:
 - INSERTION FORCE : 0.3~2.5 KGF
 - WITHDRAWAL FORCE : 1.0~2.5 KGF
- LIFE TEST: 5,000 CYCLES MIN.
- OTHER GENERAL SPEC. TO REFER "2DC-S228-B13 SPEC".
- TO CONFORM TO SINGATRON HAZARDOUS SUBSTANCE FREE SPEC.
- HALOGEN FREE PRODUCT IDENTIFICATION MARK ON JACK: ○
- HALOGEN FREE PRODUCT IDENTIFICATION LABEL ON PACKING: ●
- FOR REFLOW SOLDERING LEAD-FREE PROCESS.
- MEASURING CONDITION :

TEMPERATURE: FROM 5°C TO 35°C.
RELATIVE HUMIDITY: FROM 40% TO 85%.

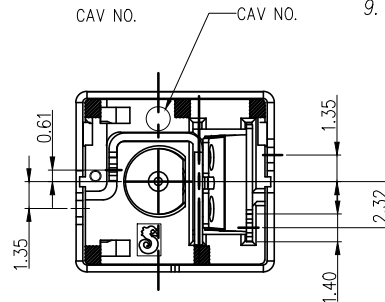
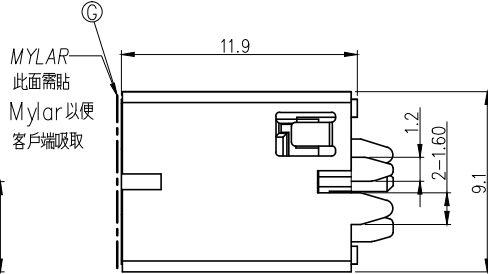
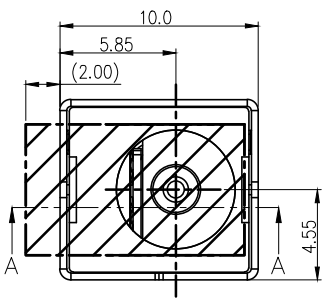

YYMMDD
 DD: DAY
 MM: MONTH
 YY: YEAR

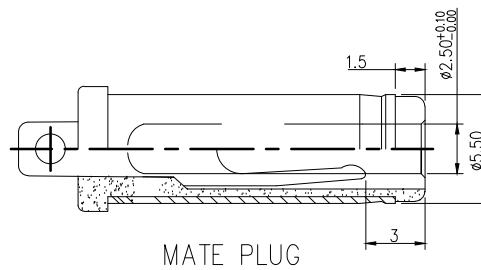
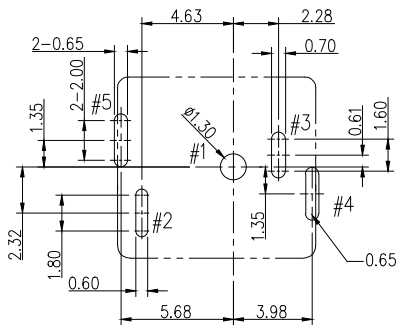
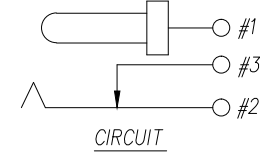

RECOMMENDED P.C.B LAYOUT (THICKNESS 1.5±0.1)
 TOP VIEW (TOLERANCE IS ±0.05)

G	MYLAR	1	INSULATION FILM 0.075t	TRANSPARENT
F	SHIELD	1	BRASS 0.35t	可鍍NI
E	TERMINAL	1	HIGH TEMP. THERMPLASTIC	COLOR: BLACK
D	SHUNT TERMINAL	1	BRASS 0.4t	Ag20u"Min, Ni底 60u"Min.
C	CONTACT PIN	1	BRASS 2.5	Ag20u"Min, Ni底 60u"Min.
B	TIP SPRING	1	COPPER ALLOY 0.3t	Ag20u"Min, Ni底 60u"Min.
A	BODY	1	HIGHT TEMP. THERMOPLASTIC UL94V-0	BLACK COLOR
NO	DESCRIPTION	QTY	MATERIAL	PLATING & COLOR
UNLESS OTHERWISE SPECIFIED TOLERANCES		Singatron Enterprise Co., Ltd. 信音企業股份有限公司		
DECIMALS: ANGLES:		TITLE: DC POWER JACK		
X : ±0.5	X : ±2°	DWN	YUREN	PART NO. 2DC-S228-B19F
X.X : ±0.3	X.X : ±1°	CHKD	CERRY	SCALE 1:1 UNIT: mm
X.XX : ±0.2		APVD	LIAO	SIZE: A3 SHEET: 10F1 REV: B
CUSTOMER COPY				