

| REV. | ECN NO OR DESCRIPTION | REVISED | DATE |
|------|---------------------------------------|------------|------------|
| A | PRODUCT RELEASE | TANGHUI | 01/14'08 |
| B | ADD GREEN PRODUCT IDENTIFICATION MARK | KENSON | 8/18'09 |
| C | ECN NO:C100420 Modify Drawing | LONGJAIING | 2010.10.26 |

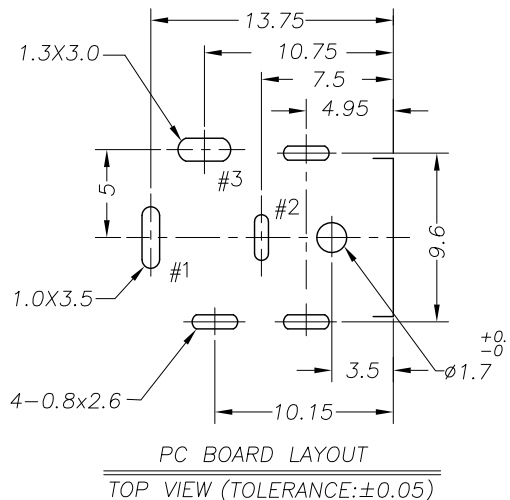

SPECIFICATIONS:

- RATING: DC 20V 9A
- INSERTION FORCE: 0.2KG-2KG
WITHDRAWAL FORCE: 0.2KG-2.0KG
- INSULATION RESISTANCE BETWEEN ANY ADJACENT TERMINALS SHALL NOT BE LESS THAN 100 MEGOHMS BY 500 VOLTS MEGGER.
- JACK SHALL WITHSTAND 250 VOLTS BETWEEN ANY ADJACENT TERMINAL FOR ONE MINUTE.
- CONTACT RESISTANCE SHALL NOT EXCEED 0.03 OHMS.
- JACK SHALL WITHSTAND 5,000 CYCLES OF INSERTION AND WITHDRAWAL WITH TESTING PLUG, AND CONTACT RESISTANCE SHALL NOT EXCEED 0.1 OHMS.
- MEASURING CONDITION:
TEMPERATURE: FROM 5°C TO 35°C.
RELATIVE HUMIDITY: FROM 40% TO 85%.
- ENVIRONMENTAL SPECIFICATIONS:
8.1 HUMIDITY TEST: HUMIDITY 90% TO 95% TEMPERATURE 40°C ± 2°C FOR 96 HOURS.
8.2 HEAT TEST: TEMPERATURE 70°C ± 2°C (HUMIDITY BELOW 50%) FOR 96 HOURS.
8.3 COLD TEST: TEMPERATURE -40°C ± 2°C FOR 96 HOURS.
- PACKING: TAPE & REEL
- TO CONFORM TO THE SINGATRON HSF SPECIFICATION.
- GREEN PRODUCT IDENTIFICATION MARK ON JACK:
- GREEN PRODUCT IDENTIFICATION LABEL ON PACKING: **G.P. PASS**
- FOR LEAD-FREE PROCESS.

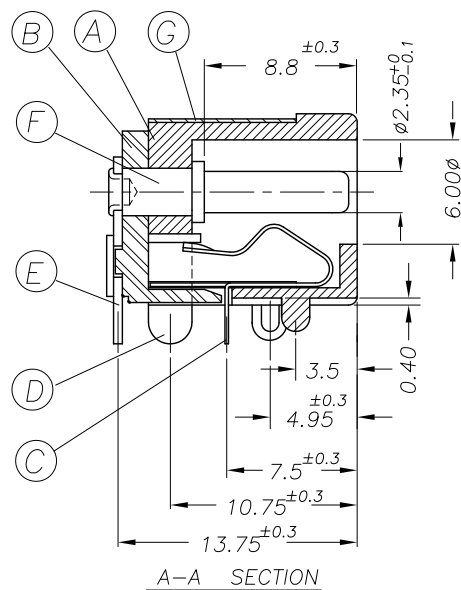
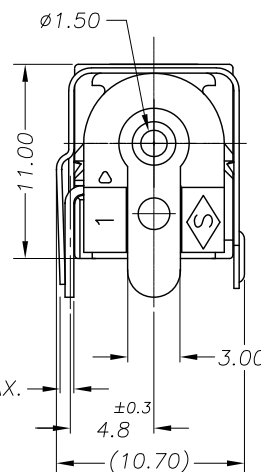
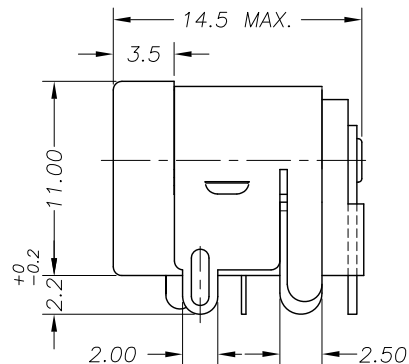
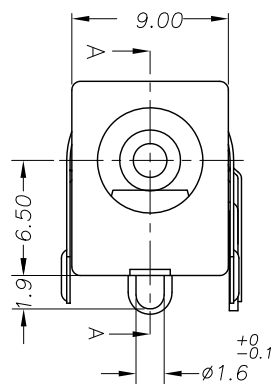
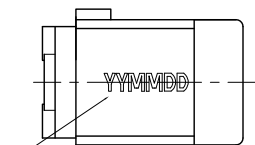

DATE CODE
YY: Year (06)
MM: Month (01~12)
DD: Day (01~31)



ELECTRICAL CIRCUIT

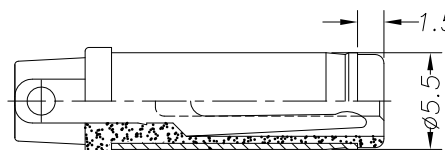

MATE PLUG $\phi 5.50$

| NO | DESCRIPTION | QTY | MATERIAL | PLATING & COLOR |
|----|----------------|-----|----------------------------------|----------------------|
| G | SHELL | 1 | COOPER ALLOY 0.3t | Ni 60u"MIN. |
| F | PIN | 1 | COOPER ALLOY | Ni60u"MIN, Cu80u"MIN |
| E | TERMINAL | 1 | COOPER ALLOY 0.5t | Ag20u"MIN, Ni20u"MIN |
| D | SHUNT TERMINAL | 1 | COOPER ALLOY 0.5t | Ag20u"MIN, Ni20u"MIN |
| C | TIP SPRING | 1 | COPPER ALLOY 0.3t | Ag20u"MIN, Ni20u"MIN |
| B | COVER | 1 | HIGHT TEMP.THERMDPLASTIC UL94V-0 | BLACK COLOR |
| A | BODY | 1 | HIGHT TEMP.THERMDPLASTIC UL94V-0 | BLACK COLOR |

UNLESS OTHERWISE SPECIFIED TOLERANCES

Singatron Electronic Co., Ltd.
信音電子企業股份有限公司

| DECIMALS: | ANGLES: | TITLE | DC POWER JACK | | |
|-------------|-----------|-------|------------------------|---------------|--|
| X : ±0.5 | X : ±2° | DWN | PART NO.: 2DC-S315-C09 | | |
| X.X : ±0.3 | X.X : ±1° | CHKD | SCALE: N/A | UNIT: mm | |
| X.XX : ±0.2 | | APVD | SIZE: A3 | SHEET: 1 OF 1 | |

CUSTOMER COPY