

REV.	ECN NO OR DESCRIPTION	REVISED	DATE
F	ECN NO. S090318	Sanming	2009.04.30
G	ECN NO.S150806-R	YUREN	2015.08.06
H	ECN NO.S160404-Q/A	YUREN	2016.05.18

SPECIFICATIONS:

- RATING: DC 20V 7A
- INSERTION FORCE: 0.4KG-3.0KG
WITHDRAWAL FORCE: 0.4KG-3.0KG
- INSULATION RESISTANCE BETWEEN ANY ADJACENT TERMINALS SHALL NOT BE LESS THAN 100 MEGOHMS BY 500 VOLTS MEGGER.
- JACK SHALL WITHSTAND 250 VOLTS BETWEEN ANY ADJACENT TERMINAL FOR ONE MINUTE.
- CONTACT RESISTANCE SHALL NOT EXCEED 0.03 Ω
- JACK SHALL WITHSTAND 5,000 CYCLES OF INSERTION AND WITHDRAWAL WITH TESTING PLUG, AND CONTACT RESISTANCE SHALL NOT EXCEED 0.1 Ω
- MEASURING CONDITION:
TEMPERATURE: FROM 5°C TO 35°C.
RELATIVE HUMIDITY: FROM 40% TO 85%
- ENVIRONMENTAL SPECIFICATIONS:
 - HUMIDITY TEST: HUMIDITY 90% TO 95% TEMPERATURE 40°C ± 2°C FOR 96 HOURS.
 - HEAT TEST: TEMPERATURE 70°C ± 2°C (HUMIDITY BELOW 50%) FOR 96 HOURS.
 - COLD TEST: TEMPERATURE -40°C ± 2°C FOR 96 HOURS.
- SOLDERABILITY TEST: THE TERMINATION IS AT LEAST 95% COVERED BY A CONTINUOUS NEW SOLDER COATING.
TEST CONDITION: DIP IN MOLTEN SOLDER FOR 5 Sec. AT 245±5°C (TERMINATION SHALL BE IMMERSED IN FLUX BEFORE TEST)
- PACKAGING: TAPE & REEL .
- TO CONFORM TO SINGATRON HAZARDOUS SUBSTANCE FREE SPEC.
- GREEN PRODUCT IDENTIFICATION MARK ON JACK:
- GREEN PRODUCT IDENTIFICATION LABEL ON PACKAGING: **G.P. PASS**
- FOR LEAD-FREE PROCESS.
- SOLDER HEAT RESISTANCE: WAVE SOLDERING 260°C 10 SECS.

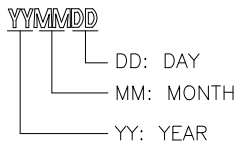
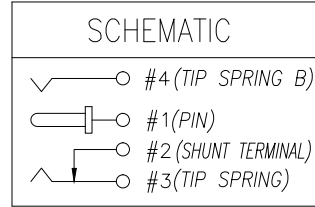
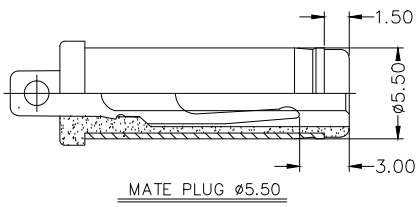
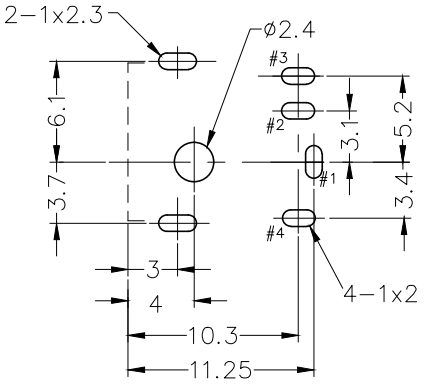
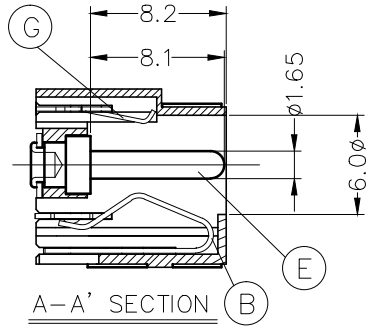
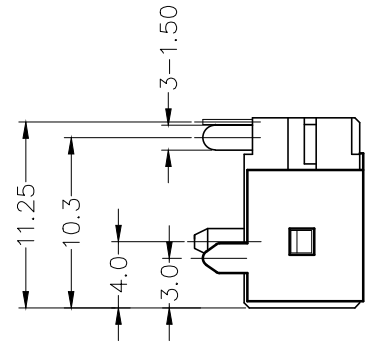
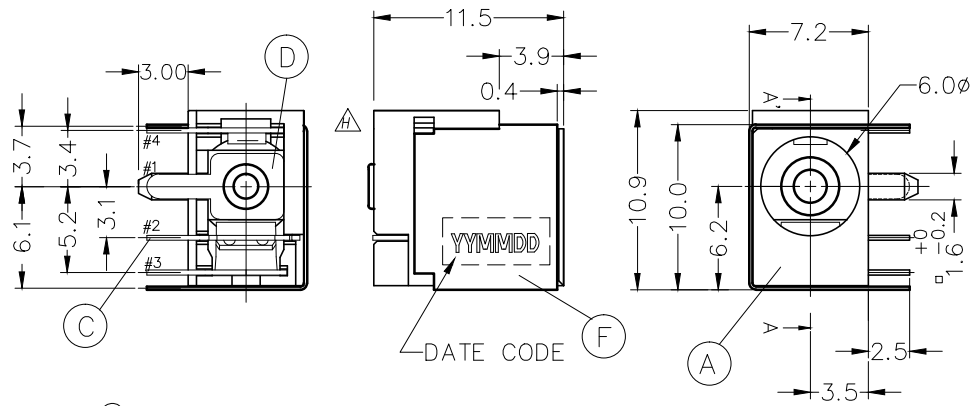

NO	DESCRIPTION	QTY	MATERIAL	PLATING & COLOR
G	TIP SPRING B	1	COPPER ALLOY 0.25t	SILVER PLATING
F	SHIELDING	1	BRASS STRIP 0.2t	NICKEL PLATING
E	PIN	1	BRASS BAR	NICKEL PLATING
D	TERMINAL	1	BRASS STRIP 0.2t	SILVER PLATING
C	SHUNT TERMINAL	1	BRASS STRIP 0.2t	SILVER PLATING
B	TIP SPRING	1	YCUTM-H 0.3T	Ag 20u" Over Ni20u"
A	BODY	1	HIGH TEMP.THERMOPLASTIC UL 94V-0	BLUE COLOR(298C)

UNLESS OTHERWISE SPECIFIED TOLERANCES		Singatron Enterprise Co., Ltd. 信音企業股份有限公司	
DECIMALS:	ANGLES:	TITLE DC POWER JACK	
X :±0.5	X :±2°	DWN	YUREN PART NO.2DC-S726-I04
X.X :±0.3	X.X :±1°	CHKD	CERRY SCALE:N/A UNIT: mm
X.XX :±0.2		APVD	LIAO SIZE: A3 SHEET:1 OF 1 REV:H
CUSTOMER COPY			