





REV.	ECN NO OR DESCRIPTION	REVISED	DATE
B	ECN NO: T080158	Even	2008.08.20
C	ECN NO: T080204	LILI	2008.12.29
D	ECN NO.S091214	Swina	2010.07.11

NOTE:  
 1. SEE 2DC1003 SERIES SPECIFICATION.  
 2. TO CONFORM TO SINGATRON HAZARDOUS SUBSTANCE FREE SPEC.  
 3. GREEN PRODUCT IDENTIFICATION MARK ON PRODUCT:   
 4. GREEN PRODUCT IDENTIFICATION LOGO ON PACKING:   
 5. FOR HAND SOLDERING LEAD-FREE PROCESS.  
 6. PRINTED DATE CODE "YYMMDD" ON TOP OF CONNECTOR.

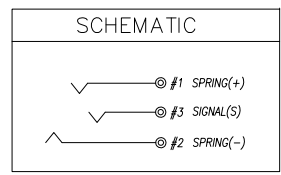
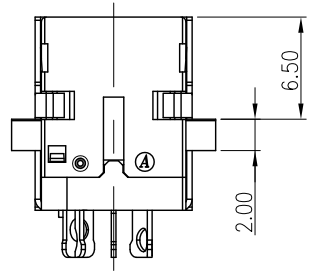
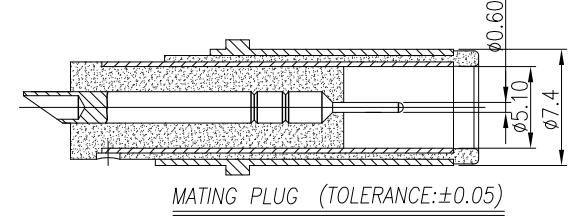
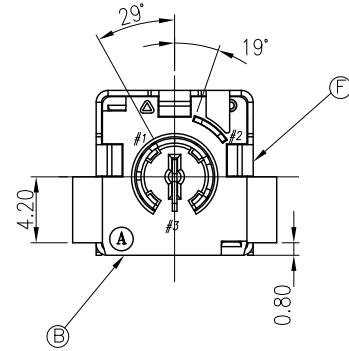
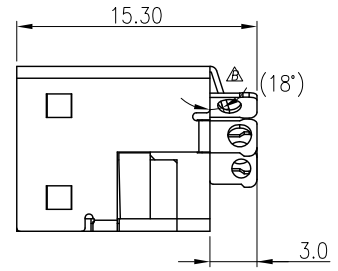
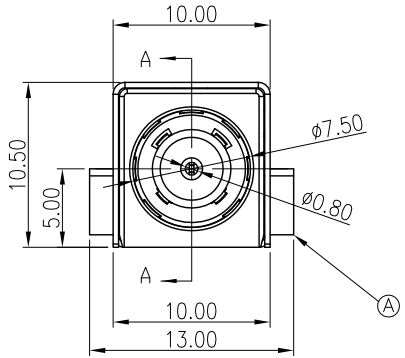
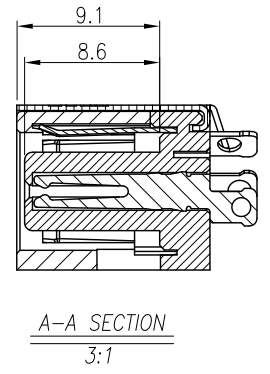
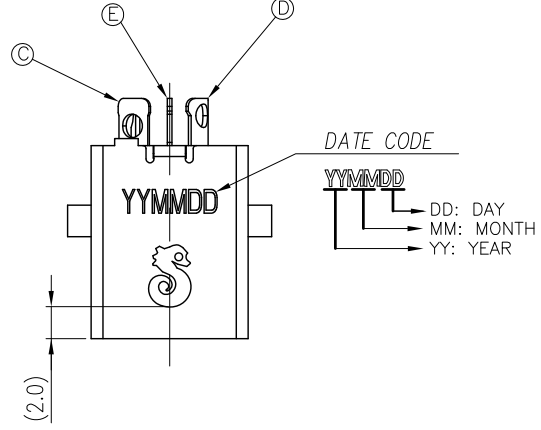

NO	DESCRIPTION	QTY	MATERIAL	PLATING & COLOR
F	SHELL	1	BRASS 0.35t	NICKEL(60u"Min.) PLATING
E	SIGNAL (S)	1	COPPER ALLOY 0.3t	GOLD FLASH(1~3u") PLATING
D	CONTACT (+)	1	COPPER ALLOY 0.3t	Gold Flash On Contact,
C	SPRING (-)	1	COPPER ALLOY 0.3t	Matt Sn 120u"Min On Solder Tail Over Ni 50u" Min.
B	COVER	1	HIGH TEMP. THERMOPLASTIC UL 94V-0	BLACK
A	HOUSING	1	HIGH TEMP. THERMOPLASTIC UL 94V-0	BLACK

UNLESS OTHERWISE SPECIFIED TOLERANCES		 Singatron Enterprise Co., Ltd. 信音企業股份有限公司		
DECIMALS:	ANGLES:	TITLE	DC POWER JACK	
X : ±0.5	X : ±2°	DWN Swina 2010.07.11	PART NO. 2DC1003-001110	
X.X : ±0.3	X.X : ±1°	CHKD Lussen	SCALE: 3:1	UNIT: mm
X.XX : ±0.2		APVD Tony	SIZE: A3	SHEET: 1 OF 1
CUSTOMER COPY				
REV: D				