

REV.	ECN NO OR DESCRIPTION	REVISED	DATE
A	PNR NO. T110301-4A	Yang	2011.03.23

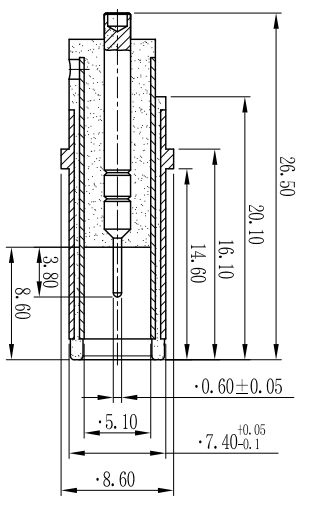
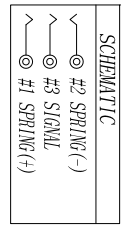
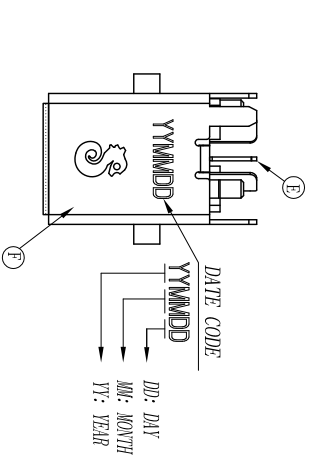

SPECIFICATIONS:

1. ELECTRICAL CHARACTERISTICS:
- 1-1. RATING: 20V 13A
  - 1-2. CONTACT RESISTANCE: 20m Ω MAX. (INITIAL)
  - 1-3. DIELECTRIC WITHSTANDING VOLTAGE: 150V AC FOR ONE MINUTE.
  - 1-4. INSULATION RESISTANCE: 100M Ω MIN. MEASURED BY 500 VDC
2. MECHANICAL CHARACTERISTICS:
- 2-1. INSERTION FORCE: 3.0 Kgf Max.
  - 2-2. WITHDRAWAL FORCE: 0.35 Kgf Min.
3. LIFE TEST: 5,000 CYCLES MIN.
4. OTHER GENERAL SPEC. TO REFER "20C1003 SERIES SPEC".
5. TO CONFORM TO SINGATRON HAZARDOUS SUBSTANCE FREE SPEC.
6. HALOGEN FREE PRODUCT IDENTIFICATION MARK
7. HALOGEN FREE PRODUCT IDENTIFICATION LOGO ON PACKAGING:
8. FOR BERTON SOLDERING LEAD-FREE PROCESS.

ON PRODUCT:

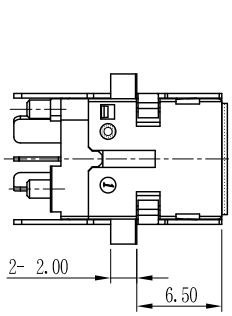
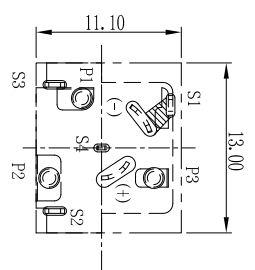
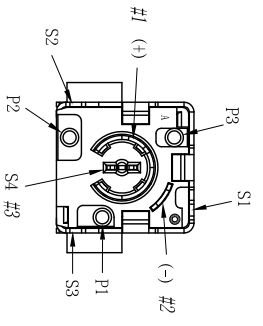
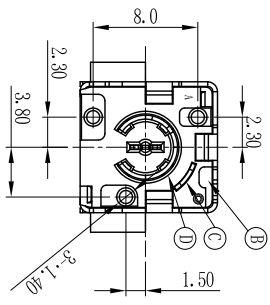
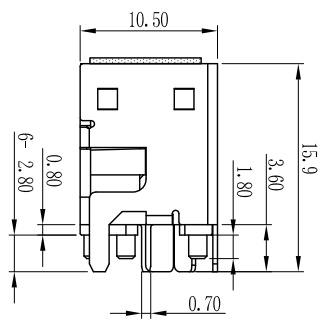
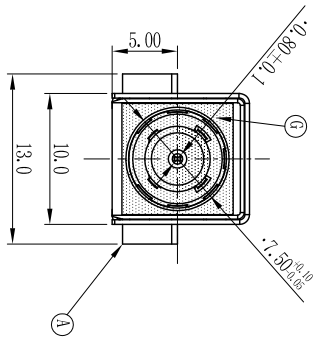

THE ABBA CAN WELD (COMPRESSIBLE SPRING (-) & SHELL)

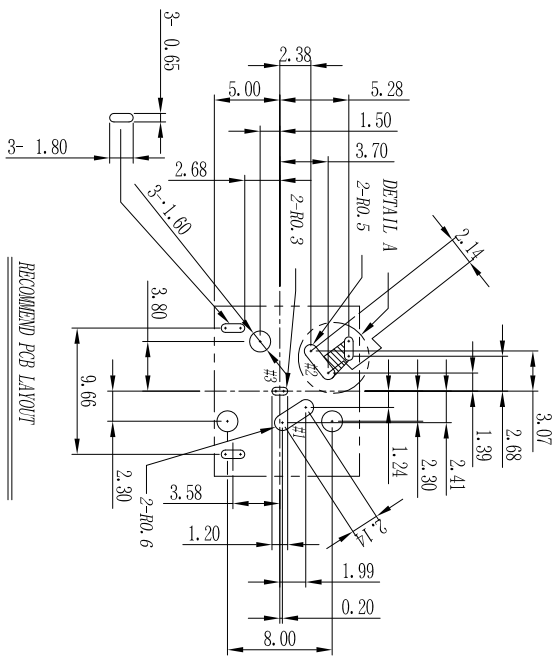
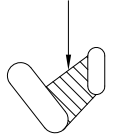

G	INSULATION FILM	1	NYLAR 0.075T	TRANSPARENT
F	SHELL	1	BRASS 0.35T	VICOR (600 "Min.") PLATING
E	SIGNAL	1	COPPER ALLOY 0.3T	IN 30" ON CONTACT AREA
D	SPRING (+)	1	COPPER ALLOY 0.3T	Sn 120μ" ON SOLDER TAIL
C	SPRING (-)	1	COPPER ALLOY 0.3T	ALL OVER IN 50μ"
B	COVER	1	HIGH TEMP. THERMOPLASTIC	BLACK
A	HOUSING	1	HIGH TEMP. THERMOPLASTIC	BLACK
NO	DESCRIPTION	1	MATERIAL	PLATING & COLOR

UNLESS OTHERWISE SPECIFIED TOLERANCES

Singatron Enterprise Co., Ltd.  
信音企業股份有限公司

DECIMALS:		ANGLES:	
X	: ± 0.5	X	: ± 2°
K.X	: ± 0.3	K.X	: ± 1°
K.XX	: ± 0.2		
TITLE			
DC POWER JACK			
DIV	Lang	PART NO. 20C1003-003313F	
CHND	SKY	SCALE 4:1	UNIT: mm
APVD	Quan	SIZE: A3	SHEET: 1 OF 1
CUSTOMER COPY			