

MATING PLUG: OD $\phi 7.4$; ID $\phi 0.6$
TOLERANCE: ± 0.05

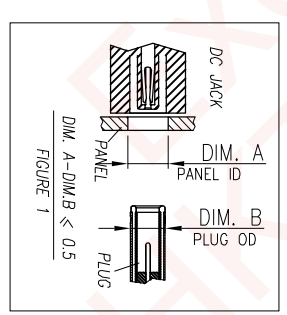
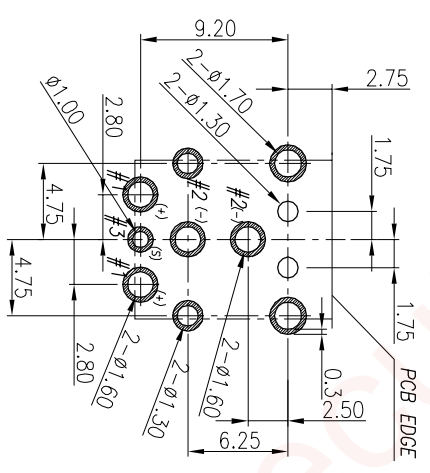
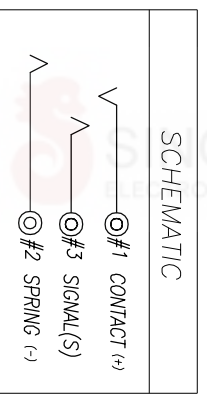
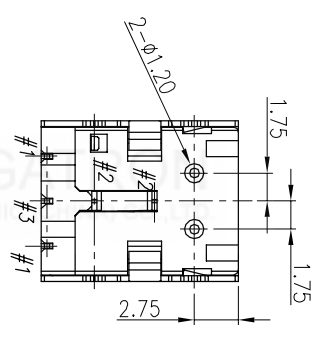

- SPECIFICATIONS:
- ELECTRICAL CHARACTERISTICS:
 - RATING: 30V 10A
 - CONTACT RESISTANCE: 20m Ω MAX.(INITIAL)
 - DIELECTRIC WITHSTANDING VOLTAGE: 150V AC FOR ONE MINUTE.
 - INSULATION RESISTANCE: 100M Ω MIN. MEASURED BY 500 VDC
 - MECHANICAL CHARACTERISTICS:
 - INSERTION FORCE: 3.0 KGf Max.
 - WITHDRAWAL FORCE: 0.35 KGf Min.
 - LIFE TEST: 5,000 CYCLES MIN.
 - OTHER GENERAL SPEC. TO REFER "ZDC1003 SERIES SPEC"
 - TO CONFORM TO SINGATRON HAZARDOUS SUBSTANCE FREE SPEC.
 - HALOGEN FREE PRODUCT IDENTIFICATION MARK ON PRODUCT:
 - HALOGEN FREE PRODUCT IDENTIFICATION LOGO ON PACKAGING:
 - FOR REFLOW SOLDERING LEAD-FREE PROCESS.
 - THE PANEL'S ID MUST BE GREATER THAN THE PLUG'S OD WHICH MUST HAVE A DIFFERENCE OF LESS THAN OR EQUAL TO 0.5 mm.(AS SHOWN IN FIGURE 1)

F	SHELL	1	BRASS 0.35t	Ni 60u"MIN.
E	SIGNAL (S)	1	COPPER ALLOY 0.3t	
D	CONTACT	1	COPPER ALLOY 0.3t	GOLD FLASH OVER Ni 50u"
C	SPRING	1	COPPER ALLOY 0.3t	
B	COVER	1	HIGH TEMP. THERMOPLASTIC UL 94V-0	BLACK
A	HOUSING	1	HIGH TEMP. THERMOPLASTIC UL 94V-0	BLACK
NO	DESCRIPTION	QTY	MATERIAL	PLATING & COLOR
UNLESS OTHERWISE SPECIFIED TOLERANCES				
Singatron Enterprise Co., Ltd. 信晋企业股份有限公司				
DECIMALS: ANGLES:				
X	: ± 0.5	X	: $\pm 2^\circ$	
X.X	: ± 0.3	X.X	: $\pm 1^\circ$	
X.XX	: ± 0.2			
TITLE DC POWER JACK				
DWN	Wenshuo	PART NO.	ZDC1003-027111F	
CHKD		SCALE:	3:1	UNIT: mm
APVD		SIZE:	A3	SHEET: 10F2
REV: A				
CUSTOMER COPY				

REV.	ECN NO.	OR DESCRIPTION	REVISED	DATE
A	PDR NO: T151023-3A		Wenshuo	2016.01.25

1. 負極彈簧片接觸狀態

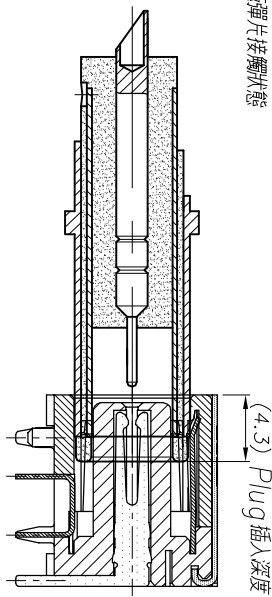

2. 正極接觸狀態

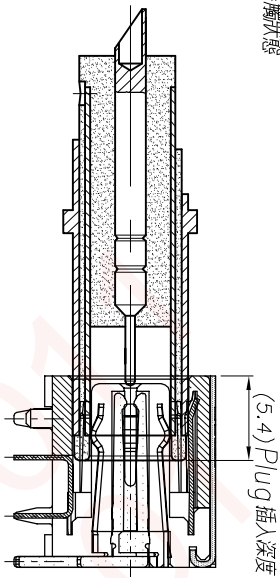

3. 訊號端子接觸狀態

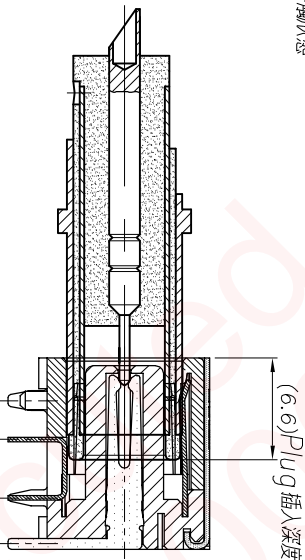

4. Plug 插至定位狀態

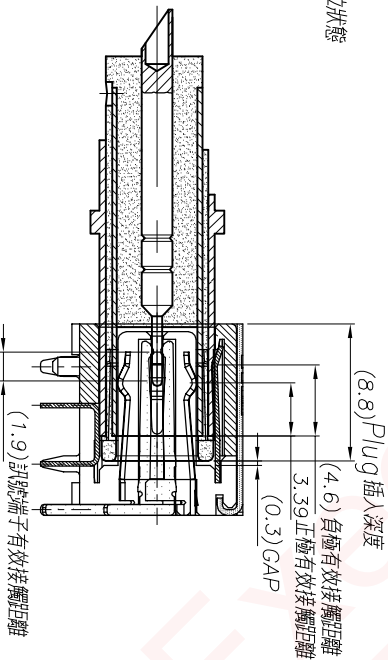

REV.	ECN NO.	OR DESCRIPTION	REVISED	DATE
A	PDR NO:1151023-3A		Wenshuo	2016.01.25

NO.	DESCRIPTION	QTY	MATERIAL	PLATING & COLOR
	UNLESS OTHERWISE SPECIFIED TOLERANCES			
	DECIMALS:			
X	:±0.5	X	:±2°	
X.X	:±0.3	X.X	:±1°	
X.XX	:±0.2			
	TITLE	DC JACK		
DWN	Wenshuo	PART NO.	ZDC1003-027111F	
CHKD		SCALE	1:1 UNIT: mm	
APVD		SIZE:	A3	SHEET: 20F2
				REV: A

CUSTOMER COPY