

REV.	ECN NO.	OR DESCRIPTION	REVISED	DATE
A	PDR	NO:TT30108-1A	Ron	2013.05.06

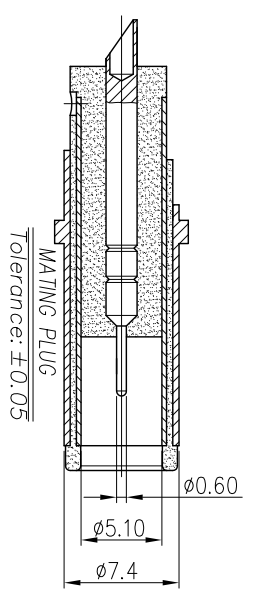

- SPECIFICATIONS:**
- ELECTRICAL CHARACTERISTICS:
 - RATING: 42V 10A
 - CONTACT RESISTANCE: 30m MAX (INITIAL)
 - DIELECTRIC WITHSTANDING VOLTAGE: 150V AC FOR ONE MINUTE.
 - INSULATION RESISTANCE: 100M Ω/MIN. MEASURED BY 500 VDC
 - MECHANICAL CHARACTERISTICS:
 - INSERTION FORCE: 3.0 KGF MAX
 - WITHDRAWAL FORCE: 0.35~3.5KGF
 - LIFE TEST: 5,000 CYCLES MIN.
 - OTHER GENERAL SPEC. TO REFER "2DC1003-031111F SPEC".
 - TO CONFORM TO SINGATRON HAZARDOUS SUBSTANCE FREE SPEC.
 - HALOGEN FREE PRODUCT IDENTIFICATION MARK ON JACK: Ⓢ
 - HALOGEN FREE PRODUCT IDENTIFICATION LABEL ON PACKAGING: ♻️
 - FOR REFLOW SOLDERING LEAD-FREE PROCESS.
 - THE PANEL'S ID MUST BE GREATER THAN THE PLUG'S OD WHICH MUST HAVE A DIFFERENCE OF LESS THAN OR EQUAL TO 0.5 mm.(AS SHOWN IN FIGURE 1.)

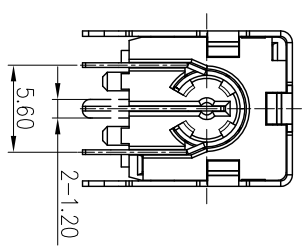
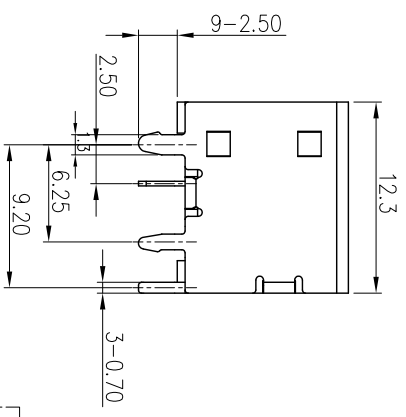
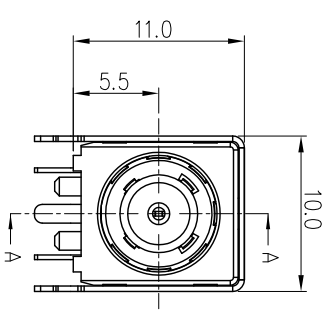
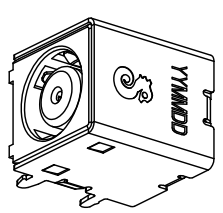
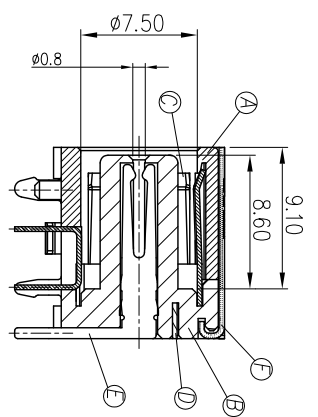
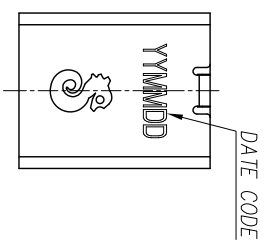
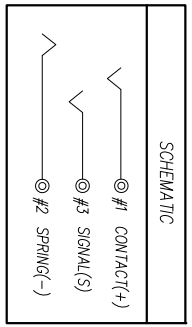
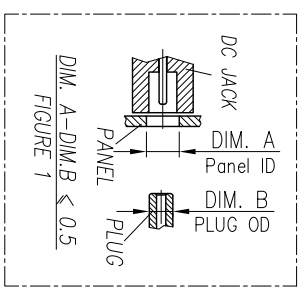
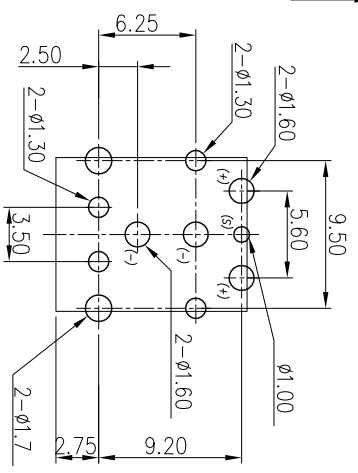
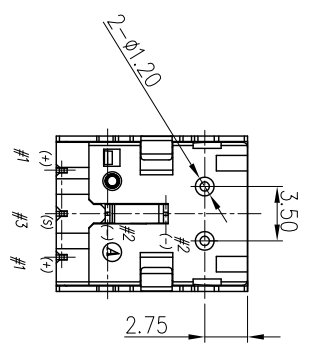

NO	DESCRIPTION	QTY	MATERIAL	PLATING & COLOR
F	SHELL	1	BRASS 0.35T	NICKEL
E	SIGNAL (S)	1	COPPER ALLOY 0.3T	AU 50U" ON CONTACT AREA, GOLD FLASH ON SOLDER AREA,
D	CONTACT (+)	1	COPPER ALLOY 0.3T	ALL OVER NI 50U"
C	SPRING (-)	1	COPPER ALLOY 0.3T	ALL OVER NI 50U"
B	COVER	1	HIGH TEMP. THERMOPLASTIC UH 94V-0	BLACK
A	HOUSING	1	HIGH TEMP. THERMOPLASTIC UH 94V-0	BLACK

UNLESS OTHERWISE SPECIFIED TOLERANCES		SINGATRON ENTERPRISE CO., LTD.	
DECIMALS:	ANGLES:	信亨企業股份有限公司	
X : ±0.5	X : ±2°	Singatron Enterprise Co., Ltd. 信亨企業股份有限公司	
XX : ±0.3	XX : ±1°		
XXX : ±0.2			
TITLE	DC POWER JACK		
DWM	Ron	PART NO. 2DC1003-031111F	
CHKD	Smile	SCALE 4:1	UNIT: mm
APVD	Lussen	SIZE: A3	SHEET: 1 OF 1
CUSTOMER COPY			