

REV.	ECN NO OR DESCRIPTION	REVISED	DATE
A	PDR NO.:T170428-1A	Wenshuo	2018.01.30
B	ECN NO.:S180931-C	Ken	2018.10.30

1. 負極接觸狀態

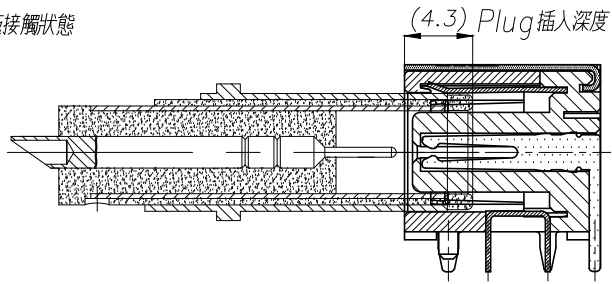

4. Full Mating 狀態

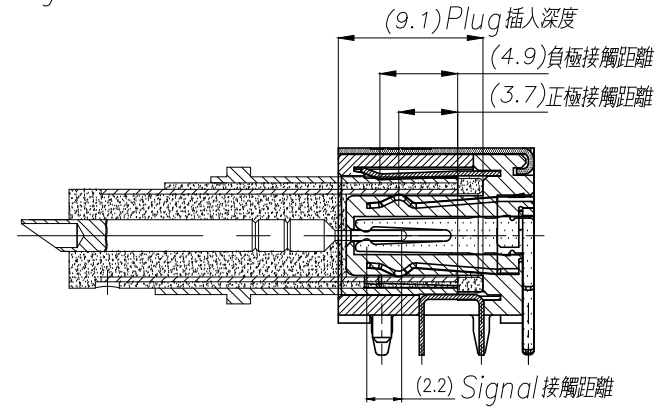

2. 正極接觸狀態

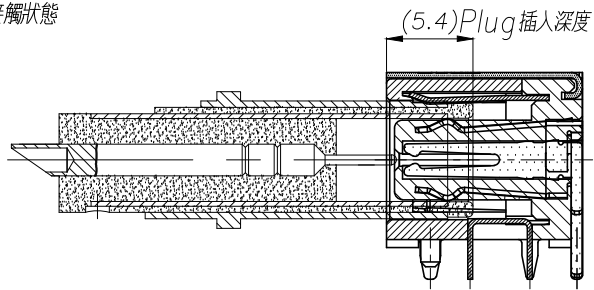

3. Signal 接觸狀態

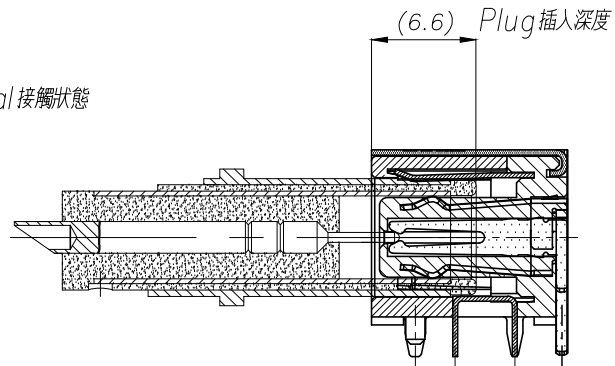

NO	DESCRIPTION	QTY	MATERIAL	PLATING & COLOR
UNLESS OTHERWISE SPECIFIED TOLERANCES		 Singatron Enterprise Co., Ltd. 信音企業股份有限公司		
DECIMALS:	ANGLES:	TITLE	DC JACK	
X :±0.5	X :±2°	DWN Ken	PART NO.2DC1003-039111F	
X.X :±0.3	X.X :±1°	CHKD sky	SCALE 1:1	UNIT: mm
X.XX :±0.2		APVD lussen	SIZE: A3	SHEET: 2 OF 2
CUSTOMER COPY				
REV: B				

1 2 3 4 5 6 7 8

REV.	ECN NO OR DESCRIPTION	REVISED	DATE
A	PDR NO.:T170428-1A	Wenshuo	2018.01.30
B	ECN NO.:S180931-C/A	Ken	2018.10.30

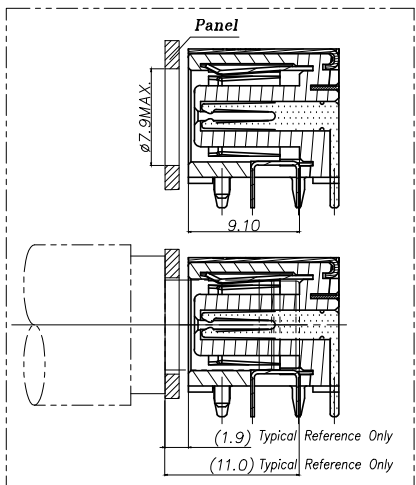
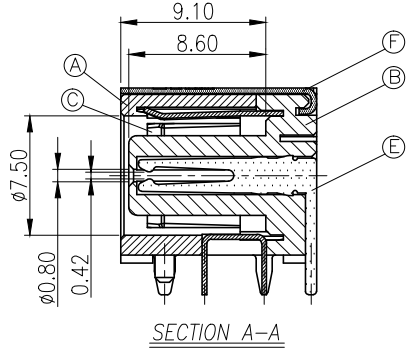
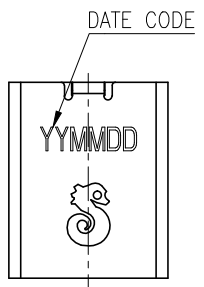

- SPECIFICATIONS:
- ELECTRICAL CHARACTERISTICS:
    - RATING: 30V 10A
    - CONTACT RESISTANCE: 20mΩ MAX.(INITIAL)
    - DIELECTRIC WITHSTANDING VOLTAGE: 150V AC FOR ONE MINUTE.
    - INSULATION RESISTANCE: 100MΩ MIN. MEASURED BY 500 VDC
  - MECHANICAL CHARACTERISTICS:
    - INSERTION FORCE : 3.0 KGF Max.
    - WITHDRAWAL FORCE : 0.35 KGF Min.
  - LIFE TEST: 5,000 CYCLES MIN.
  - OTHER GENERAL SPEC. TO REFER "2DC1003-039111F SPEC".
  - TO CONFORM TO SINGATRON HAZARDOUS SUBSTANCE FREE SPEC.
  - HALOGEN FREE PRODUCT IDENTIFICATION MARK ON PRODUCT:
  - HALOGEN FREE PRODUCT IDENTIFICATION LOGO ON PACKAGING:
  - FOR REFLOW SOLDERING LEAD-FREE PROCESS.
  - PRINTED DATE CODE "YYMMDD" ON TOP OF CONNECTOR.  
(YY: YEAR MM: MONTH DD: DAY )

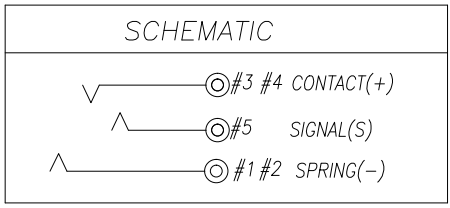
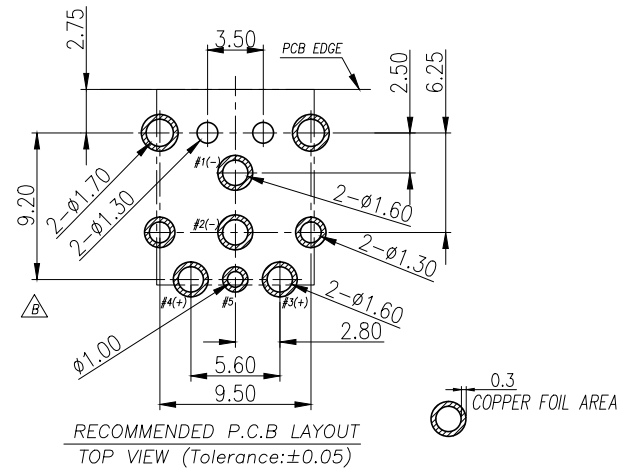
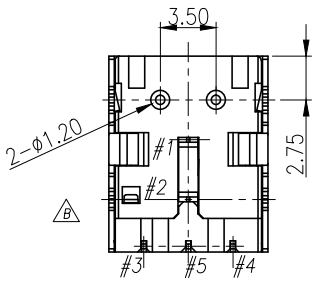
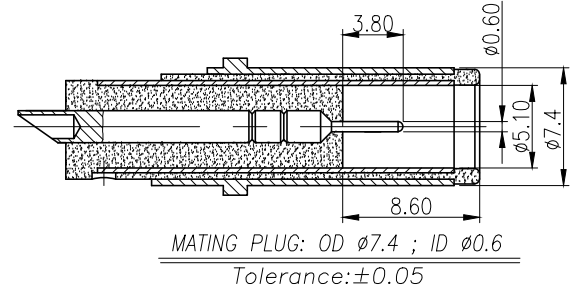
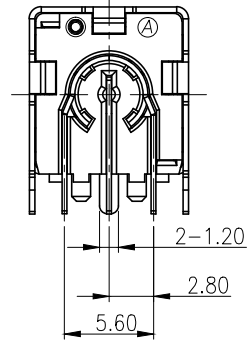
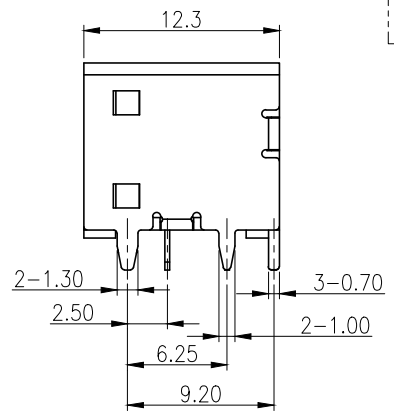
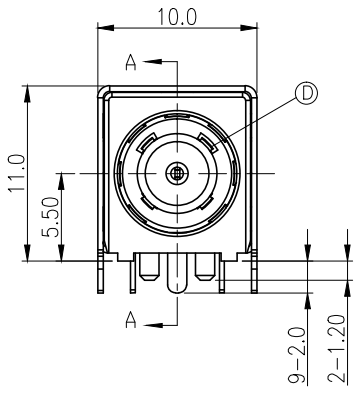

NO	DESCRIPTION	QTY	MATERIAL	PLATING & COLOR
F	SHELL	1	BRASS 0.35t	Ni 60u"MIN
E	SIGNAL (S)	1	COPPER ALLOY 0.3t	
D	CONTACT	1	COPPER ALLOY 0.3t	Gold flash on contact area; Matte Sn 120u" on Solder Tail; All over Ni 50u"
C	SPRING	1	COPPER ALLOY 0.3t	
B	COVER	1	HIGH TEMP. THERMOPLASTIC UL 94V-0	BLACK
A	HOUSING	1	HIGH TEMP. THERMOPLASTIC UL 94V-0	BLACK
UNLESS OTHERWISE SPECIFIED TOLERANCES		Singatron Enterprise Co., Ltd. 信音企業股份有限公司		
DECIMALS: ANGLES:		TITLE: DC POWER JACK		
X	: $\pm 0.5$	X	: $\pm 2^\circ$	DWN Ken PART NO. 2DC1003-039111F
X.X	: $\pm 0.3$	X.X	: $\pm 1^\circ$	CHKD sky SCALE: 3:1 UNIT: mm
X.XX	: $\pm 0.2$			APVD lussen SIZE: A3 SHEET: 1 OF 2 REV: B
CUSTOMER COPY				

1 2 3 4 5 6 7 8