

REV.	ECN NO OR DESCRIPTION	REVISED	DATE
A	PDR NO: T191118-1A	Sugar	2020.04.29

SPECIFICATIONS:

- ELECTRICAL CHARACTERISTICS:
  - RATING: 20V 13A
  - CONTACT RESISTANCE: 20mΩ MAX.(INITIAL), 30mΩ MAX.(FINAL)
  - DIELECTRIC WITHSTANDING VOLTAGE: 150V AC FOR ONE MINUTE.
  - INSULATION RESISTANCE: 100MΩ MIN. MEASURED BY 500 VDC
- MECHANICAL CHARACTERISTICS:
  - INSERTION FORCE : 1.0~2.5KGF
  - WITHDRAWAL FORCE : 1.0~2.5KGF
- LIFE TEST: 5,000 CYCLES MIN.
- OTHER GENERAL SPEC. TO REFER "2DC1003-039313F SPEC".
- TO CONFORM TO SINGATRON HAZARDOUS SUBSTANCE FREE SPEC.
- HALOGEN FREE PRODUCT IDENTIFICATION MARK ON PRODUCT:
- HALOGEN FREE PRODUCT IDENTIFICATION LOGO ON THE PACKAGING:
- FOR REFLOW SOLDERING LEAD-FREE PROCESS.
- THE PANEL'S ID MUST BE GREATER THAN THE PLUG'S OD WHICH MUST HAVE A DIFFERENCE OF LESS THAN OR EQUAL TO 0.5 mm.(AS SHOWN IN FIGURE 1.)

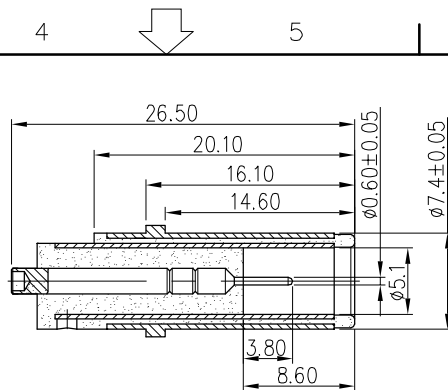
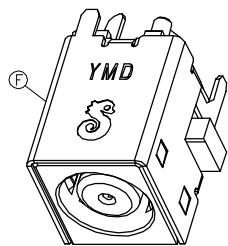
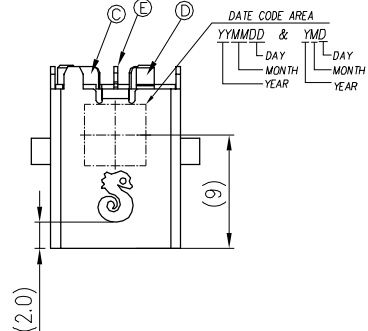

MATING PLUG  
(TOLERANCE: ±0.10)

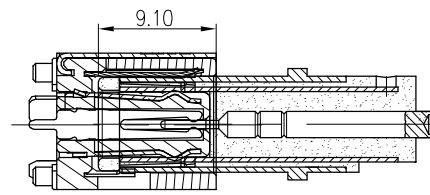
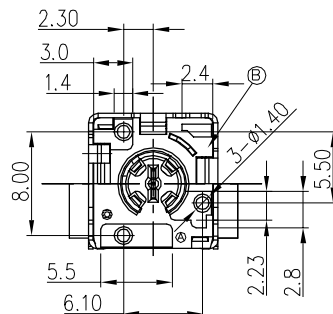
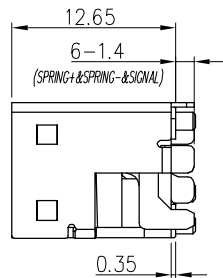
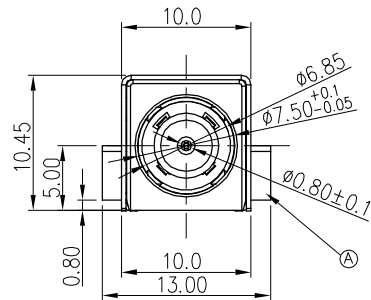

PLUG FULL MATING STATUS

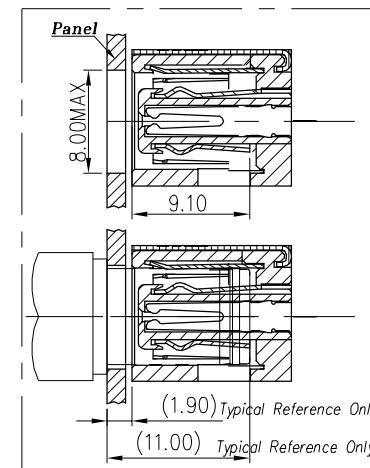

SCHEMATIC

- ~⊙ #1 SPRING(+)
- ~⊙ #2 SPRING(-)
- ~⊙ #3 SIGNAL

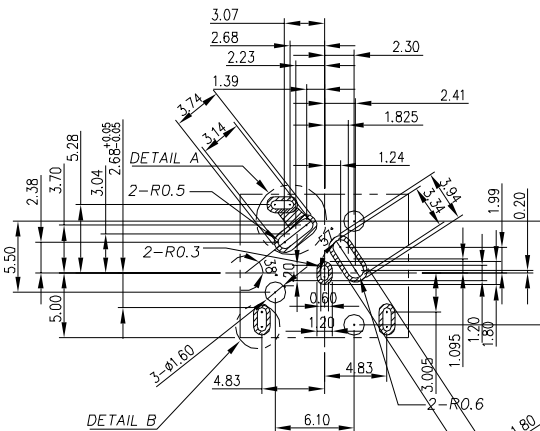
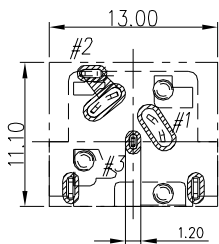
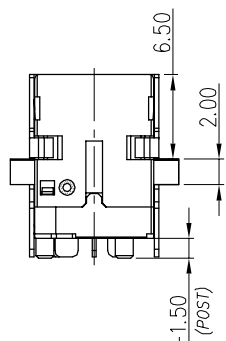

Recommended PCB Layout  
<TOP VIEW>TOLERANCE: ±0.05

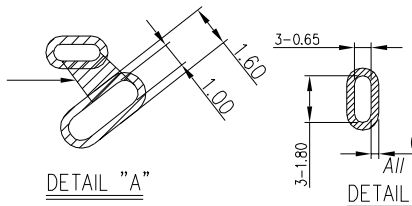

The area can weld(comprehend Spring(-)&Shell)

F	SHELL	1	C2680-H 0.35T	Ni 60u" Min.
E	SIGNAL	1	C5210-SH 0.3T	G/F ON CONTACT AREA
D	SPRING (+)	1	C7035-TM06 0.3T	Sn 80u" ON SOLDER AREA;
C	SPRING (-)	1	C7035-TM06 0.3T	ALL OVER Ni 50 u"
B	COVER	1	LCP+30%GF E130i UL 94V-0	BLACK
A	HOUSING	1	LCP+30%GF E130i UL 94V-0	BLACK
NO	DESCRIPTION	QTY	MATERIAL	PLATING & COLOR

UNLESS OTHERWISE SPECIFIED TOLERANCES

Singatron Enterprise Co., Ltd.  
信音企業股份有限公司

DECIMALS:	ANGLES:	TITLE	DC POWER JACK	
X : ±0.5	X : ±2°	DWN	Sugar	PART NO.2DC1003-039313F
X.X : ±0.3	X.X : ±1°	CHKD	Spring	SCALE 4:1 UNIT: mm
X.XX : ±0.2		APVD	Lussen	SIZE: A3 SHEET: 1 OF 2 REV:A

CUSTOMER COPY

REV.	ECN NO OR DESCRIPTION	REVISED	DATE
A	PDR NO: T191118-1A	Sugar	2020.04.29

1. 負極接觸狀態

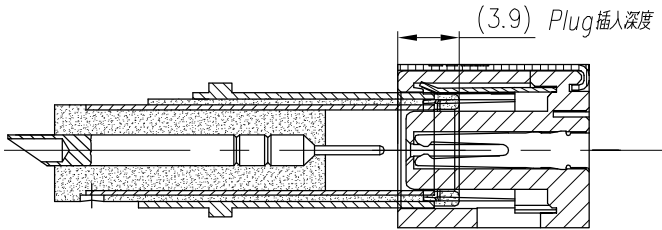

3. SIGNAL 接觸狀態

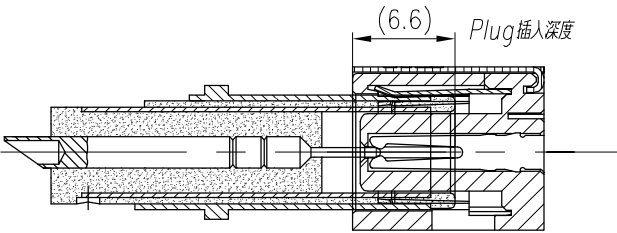

2. 正極接觸狀態

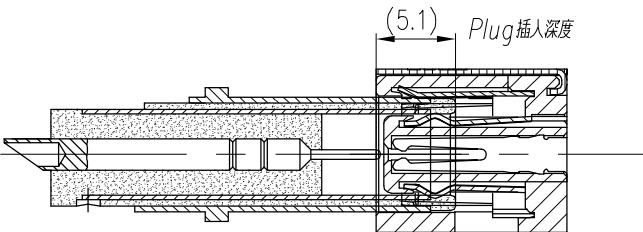

4. FULL MATING 狀態

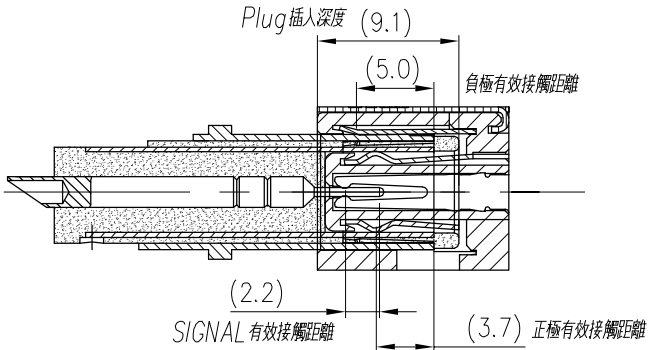

UNLESS OTHERWISE SPECIFIED TOLERANCES		Singatron Enterprise Co., Ltd. 信音企業股份有限公司	
DECIMALS:	ANGLES:	TITLE MATING DRAWING	
X : ±0.5	X : ±2°	DWN	Sugar PART NO. 2DC1003-039313F
X.X : ±0.3	X.X : ±1°	CHKD	Spring SCALE: 3:1 UNIT: mm
X.XX : ±0.2		APVD	Lussen SIZE: A3 SHEET: 2 OF 2 REV:A
CUSTOMER COPY			