

REV.	ECN NO. OR DESCRIPTION	REVISED	DATE
A	PDR NO: T110520-1A	Springwu	2011.08.01
B	ECN NO: S120771	Springkong	2012.07.30

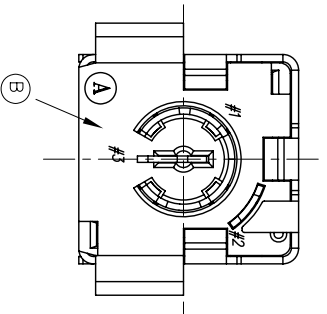

- NOTES:
- ELECTRICAL PERFORMANCES:
 - CURRENT RATING: 10A MAX.
 - CONTACT RESISTANCE: 30 mΩ MAX.
 - INSULATION RESISTANCE: 100 MΩ MIN.
 - DIELECTRIC WITHS TANDING VOLTAGE: 150V AC FOR 1 MINUTE.
 - MECHANICAL PERFORMANCES:
 - MATING FORCE: 3.0Kgf MAX.
 - UNMATING FORCE: 0.35Kgf MIN.
 - MECHANICAL OPERATION: 5000 CYCLES.
 - OPERATING TEMPERATURE: -40°C TO 85°C
 - HALOGEN FREE PRODUCT IDENTIFICATION MARK ON JACK:
 - HALOGEN FREE PRODUCT IDENTIFICATION LABEL ON PACKAGING:
 - TO CONFORM TO SINGATRON HAZARDOUS SUBSTANCE FREE SPEC.
 - FOR HAND SOLDERING LEAD-FREE PROCESS.
 - PRINTED DATE CODE "YMMDD" ON TOP OF CONNECTOR.

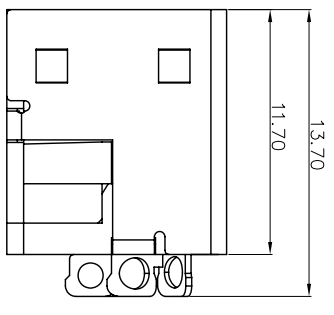
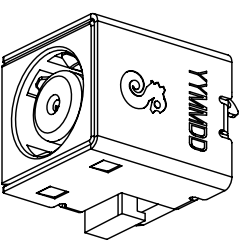
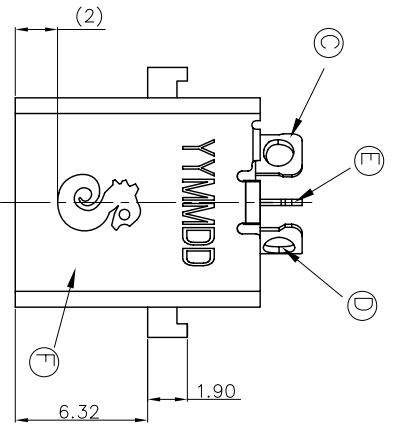
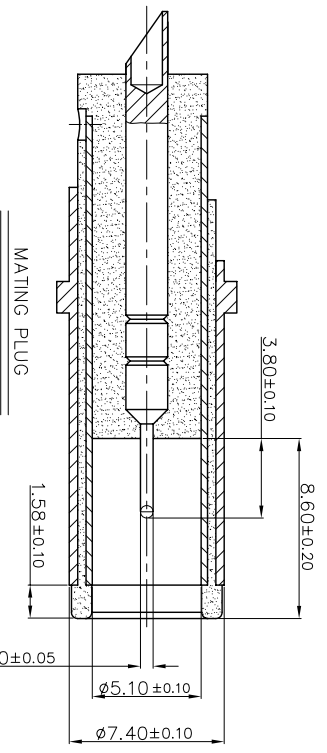
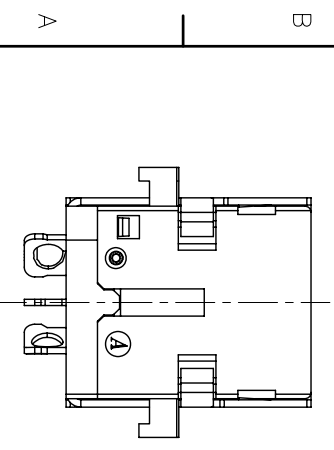
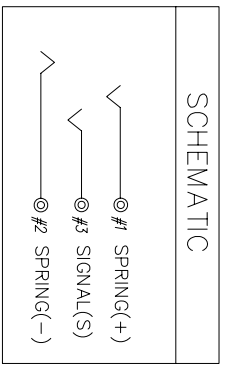
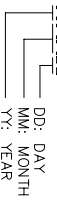

NO	DESCRIPTION	QTY	MATERIAL	PLATING & COLOR
F	SHELL	1	BRASS 0.35t	Ni 60u" Min OVER ALL.
E	SIGNAL (S)	1	COPPER ALLOY 0.3t	
D	CONTACT (+)	1	COPPER ALLOY 0.3t	Au 1~3u" PLATING OVER Ni 50u" MIN.
C	SPRING (-)	1	COPPER ALLOY 0.3t	
B	COVER	1	HIGH TEMP. THERMOPLASTICUL 94V-0	BLACK
A	BODY	1	HIGH TEMP. THERMOPLASTICUL 94V-0	BLACK
NO	DESCRIPTION			

UNLESS OTHERWISE SPECIFIED TOLERANCES

Singatron Enterprise Co., Ltd.
信普企業股份有限公司

DECIMALS:	ANGLES:	TITLE
X : ±0.5	X : ±2°	DC POWER JACK
X.X : ±0.3	X.X : ±1'	PART NO. 2DC1003-041110F
X.XX : ±0.2		Springkong

CHKD	TOM	SCALE:	UNIT:	SIZE:	SHEET:	REV:
APVD	QUAN	A3	mm	A3	1 OF 1	B

CUSTOMER COPY