

REV.	ECN NO OR DESCRIPTION	REVISED	DATE
A	PDR NO. T111230-1A	Smile	2012.05.17
B	ECN NO. S170135-Q	YUREN	2017.5.2

- SPECIFICATIONS:
- ELECTRICAL CHARACTERISTICS:
 - 1-1. RATING: 20V 3A
 - 1-2. CONTACT RESISTANCE: 30mΩ MAX.
 - 1-3. DIELECTRIC WITHSTANDING VOLTAGE: 500V AC FOR ONE MINUTE.
 - 1-4. INSULATION RESISTANCE: 100MΩ MIN. MEASURED BY 500 VDC
 - MECHANICAL CHARACTERISTICS:
 - 2-1. INSERTION FORCE: 3.5kgf MAX.
 - 2-2. WITHDRAWAL FORCE: 0.3~3.5kgf.
 - LIFE TEST: 5,000 CYCLES MIN.
 - TO CONFORM TO SINGATRON HAZARDOUS SUBSTANCE FREE SPEC.
 - GREEN PRODUCT IDENTIFICATION MARK ON JACK:
 - GREEN PRODUCT IDENTIFICATION LABEL ON PACKAGING:
 - FOR HAND SOLDERING LEAD-FREE PROCESS.
 - PRINTED DATE CODE "YYMMDD".

DD: DAY
MM: MONTH
YY: YEAR

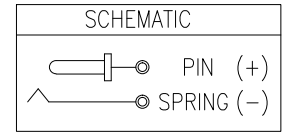

Function test mark : visible
ø0.4MAX,Depth 0.6MAX

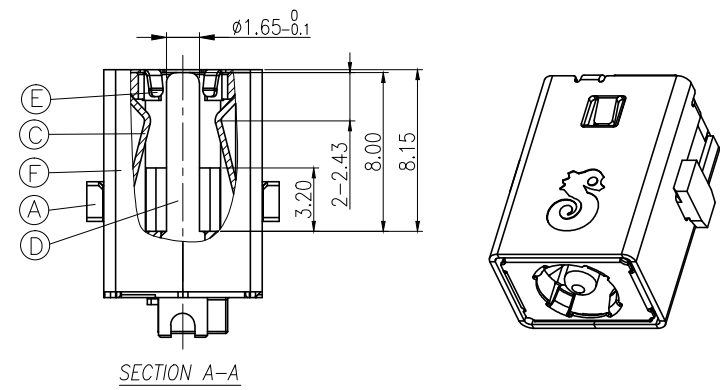
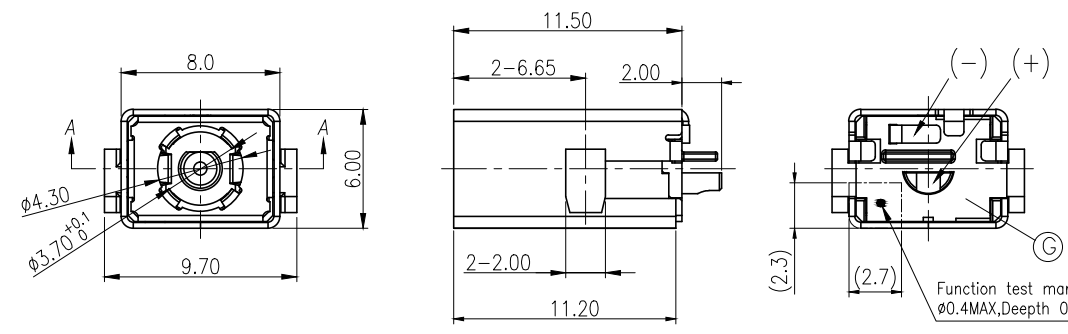
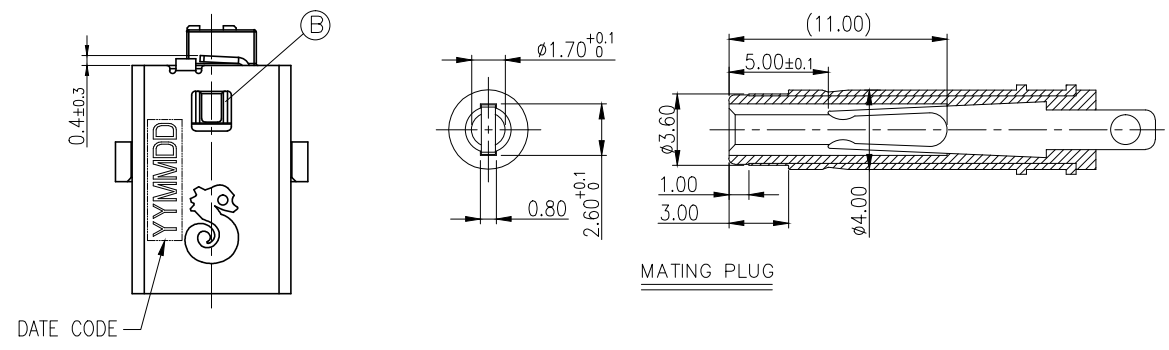

NO	DESCRIPTION	QTY	MATERIAL	PLATING & COLOR
G	COVER	1	THERMOPLASTIC UL 94V-0 (HALOGEN FREE)	BLACK
F	SHELL	1	SPCC-SB 0.30T	可焊Ni 60u"Min
E	GROUND	1	STAINLESS STEEL 0.15T	N/A
D	PIN	1	BRASS	Gold Flash Over Ni 50u"Min
C	SPRING	1	COPPER ALLOY 0.30T	Gold Flash On Contact Area. Sn 100u"Min On Solder Tail. All Over Ni 50u"Min.
B	STOPPER	1	THERMOPLASTIC UL 94V-0 (HALOGEN FREE)	BLACK
A	HOUSING	1	THERMOPLASTIC UL 94V-0 (HALOGEN FREE)	BLACK

UNLESS OTHERWISE SPECIFIED TOLERANCES

DECIMALS: ANGLES:

X :±0.5 X :±2°
X.X :±0.3 X.X :±1°
X.XX :±0.2

TITLE		DC POWER JACK	
DWN	YUREN	PART NO.	2DC1015-006111F
CHKD	CERRY	SCALE:1:1	UNIT: mm
APVD	LIAO	SIZE: A3	SHEET:1 OF 1
			REV:B

CUSTOMER COPY