

REV	ECN NO OR DESCRIPTION	REVISED	DATE
A	PRODUCT RELEASE	JASON	2009.07.25

DATE CODE
YMAAD
 DD: DAY
 MM: MONTH
 YY: YEAR

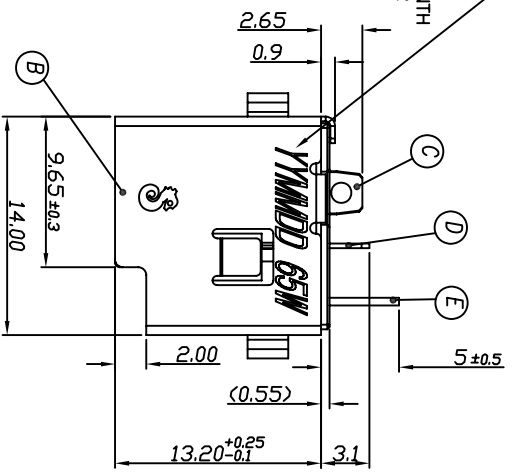

- SPECIFICATIONS:
- ELECTRICAL CHARACTERISTICS:
 - RATING: 20V 8A
 - CONTACT RESISTANCE: 30m² MAX.(INITIAL)
 - DIELECTRIC WITHSTANDING VOLTAGE: 500V AC FOR ONE MINUTE.
 - INSULATION RESISTANCE: 100M² MIN. MEASURED BY 500 VDC
 - MECHANICAL CHARACTERISTICS:
 - INSERTION FORCE : 2.5 KGf Max.
 - WITHDRAWAL FORCE : 0.6 KGf Min.
 - LIFE TEST: 5,000 CYCLES MIN.
 - OTHER GENERAL SPEC. TO REFER "ZDC1017-065211 SPEC."
 - TO CONFORM TO SINGATRON HAZARDOUS SUBSTANCE FREE SPEC.
 - GREEN PRODUCT IDENTIFICATION LABEL ON PACKAGING.
 - HALOGEN FREE PRODUCT IDENTIFICATION MARK ON JACK: ©
 - FOR HAND SOLDERING LEAD-FREE PROCESS.
 - PACKAGING: BAG

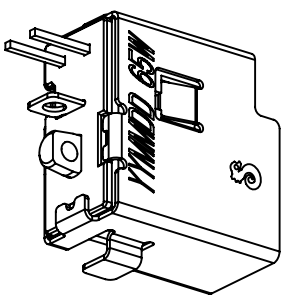
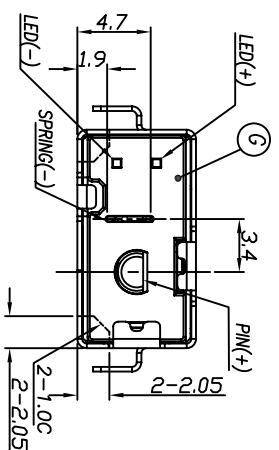
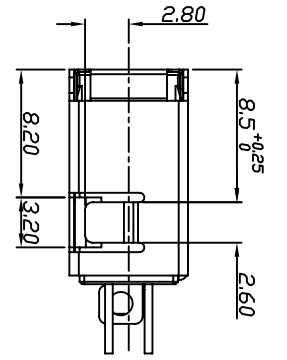
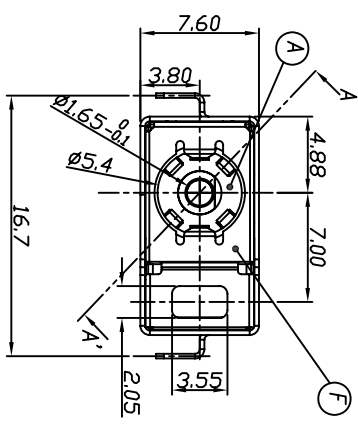
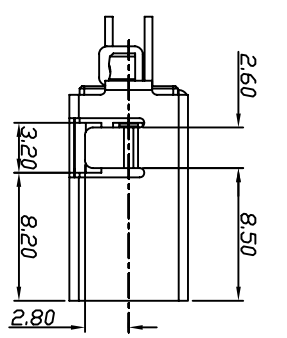

LED Soldering Condition:
 Peak Temperature: 350 °C Max.
 Soldering Iron: 3 sec Max.
 (see time only)

SCHEMATIC

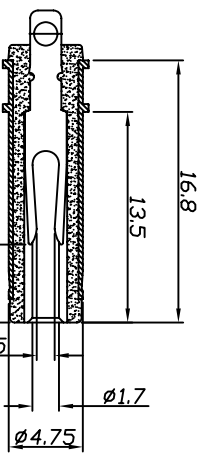
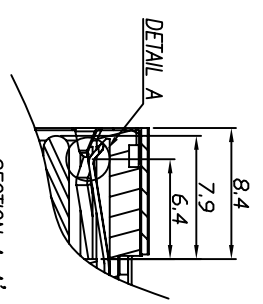

DETAIL A
SCALE 9:1

SECTION A-A'
SCALE 3:1

MATING PLUG: φ4.75 PLUG 65W
 (TOLERANCE: ±0.05)

G	BACK PLATE	1	PA-66 UL 94V-0 (HALOGEN FREE)	BLACK COLOR
F	GROUND	1	SUS301 1/2H 0.15t	N/A
E	LED	1	InCan Lamps	
D	SPRING(-)	1	CS210-EH 0.3t	OVER ALL HT: 50.7 Min. CONTACT AREA: 20.7 Min. SOLDER AREA: Sn 120 u" Min.
C	PIN	1	COPPER ALLOY(Pb-free)	OVER ALL HT: 50.7 Min. OVER ALL Au: 50.7 Min.
B	SHELL	1	SPCC 0.3t	NICKEL-PLATED (60u" Min.)
A	HOUSING	1	PA-66 UL 94V-0 (HALOGEN FREE)	BLACK COLOR
NO	DESCRIPTION	QTY	MATERIAL	PLATING & COLOR
UNLESS OTHERWISE SPECIFIED TOLERANCES				
Singatron Enterprise Co., Ltd. 信登企業股份有限公司				
TITLE: DC POWER JACK_65W				
DWG: JASON 2009.7.28 PART NO. ZDC1017-065211				
CHKD: ANGEBA 2009.7.28 SCALE: 3:1 UNIT: mm				
APVD: JAK-MU SIZE: A3 SHEET: 1 OF 1 REV: A				
CUSTOMER COPY				