

REV.	ECN NO. OR DESCRIPTION	REVISED	DATE
A	PRODUCT RELEASE	Allen	2010.09.27
B	ECN:C110138Modify Drawing	LONGJIANG	2011.05.16
C	ECN: C120105 MODIFY DRAWING	DAOWEN	2012.04.05

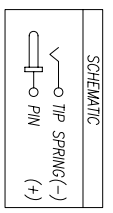

- SPECIFICATIONS:
- ELECTRICAL CHARACTERISTICS:
 - RATING: 20V, 3A Min.
 - CONTACT RESISTANCE: 30 MILLIOHMS Max. FOR INITIAL, 50 MILLIOHMS Max. AFTER 5000 CYCLES.
 - INSULATION RESISTANCE: 100 MEGAOHMS Min. BY 500V DC AFTER 1 MINUTE.
 - DIELECTRIC WITHSTANDING VOLTAGE: 500V RMS AFTER 1 MINUTE.
 - MECHANICAL CHARACTERISTICS:
 - INSERTION FORCE : 0.4~3.0 KGF
 - WITHDRAWAL FORCE : 0.4~3.0KGF
 - OTHER GENERAL SPEC. TO REFER "2DC1022 SERIES SPEC".
 - TO CONFORM TO SINGATRON HAZARDOUS SUBSTANCE FREE SPEC.
 - HALOGEN FREE PRODUCT IDENTIFICATION MARK ON PRODUCT:
 - HALOGEN FREE PRODUCT IDENTIFICATION LABEL ON PACKAGING:
 - PACKAGING: BAG
 - FOR HAND SOLDERING LEAD-FREE PROCESS.

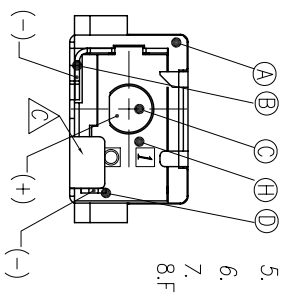
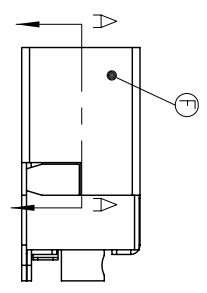
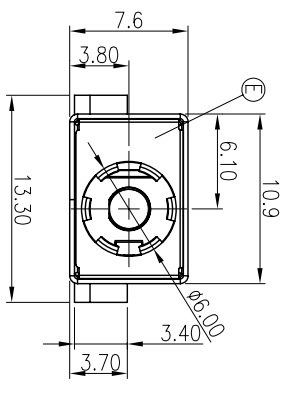
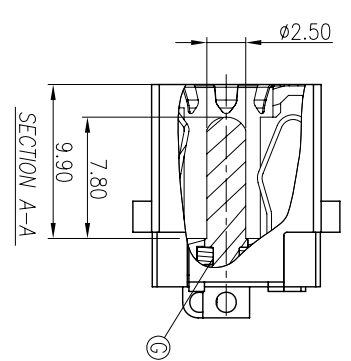
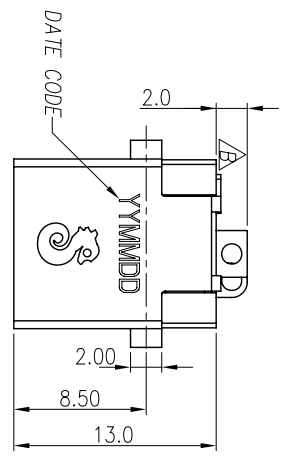
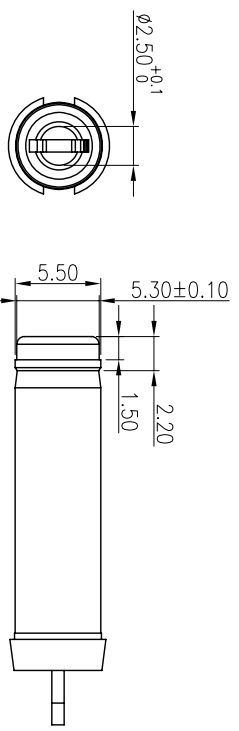
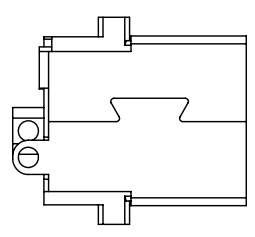

MATING PLUG
(TOLERANCE ±0.05)

H	COVER	1	THERMOPLASTIC UL 94V-0	BLACK COLOR
G	STOPPER	1	THERMOPLASTIC UL 94V-0	BLACK COLOR
F	SHELL	1	SPCC 0.3T	NICKEL-PLATED
E	GROUND	1	STAINLESS 0.1t	N/A
D	TIP SPRING	1	COPPER ALLOY 0.3T	GOLD FLASH AT CONTACT AREA
C	PIN	1	BRASS	GOLD FLASH
B	SPRING	1	COPPER ALLOY 0.3T	GOLD FLASH AT CONTACT AREA
A	HOUSING	1	THERMOPLASTIC UL 94V-0	BLACK COLOR
NO	DESCRIPTION	QTY	MATERIAL	PLATING & COLOR

UNLESS OTHERWISE SPECIFIED TOLERANCES

Singatron Enterprise Co., Ltd.
信音企業股份有限公司

DECIMALS:	ANGLES:
X :±0.5	X :±2°
X.X :±0.3	X.X :±1°
X.XX :±0.2	

TITLE	DC POWER JACK
DWN	DATE: 2012/04/05
CHKD	ZZT
APVD	UWQ
	SCALE: 3:1
	SIZE: A3
	SHEET: 1 OF 1
	REV: C

CUSTOMER COPY