

REV.	ECN NO OR DESCRIPTION	REVISED	DATE
A	PDR NO. T220222-3A	Huanhuan	2023.02.08

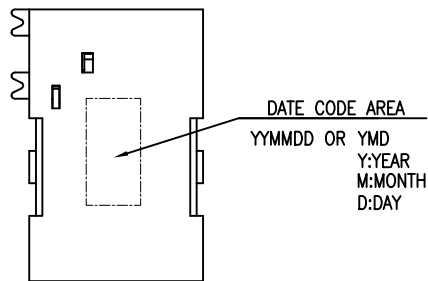

SPECIFICATIONS:

- ELECTRICAL CHARACTERISTICS:**
 - 1-1. RATING: 18V 3.5A.
 - 1-2. CONTACT RESISTANCE: 30mΩ MAX.
 - 1-3. DIELECTRIC WITHSTANDING VOLTAGE: 500V AC FOR ONE MINUTE.
 - 1-4. INSULATION RESISTANCE: 100MΩ MIN. MEASURED BY 500 VDC
- MECHANICAL CHARACTERISTICS:**
 - 2-1. INSERTION FORCE : 0.5~2.5 kgf (INITIAL / AFTER LIFE TEST)
 - 2-2. WITHDRAWAL FORCE : 0.5~2.5 kgf (INITIAL / AFTER LIFE TEST)
- TEMPERATURE RISE CAN'T EXCEE 30°C
- LIFE TEST: 5,000 CYCLES MIN.
- OTHER GENERAL SPEC. TO REFER "2DC1503-002111F SPEC".
- TO CONFORM TO SINGATRON HAZARDOUS SUBSTANCE FREE SPEC.
- HALOGEN FREE PRODUCT IDENTIFICATION MARK ON JACK:
- HALOGEN FREE PRODUCT IDENTIFICATION LABEL ON PACKAGING:
- FOR REFLOW SOLDERING LEAD-FREE PROCESS.

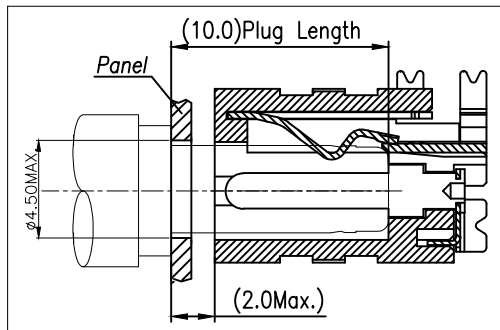
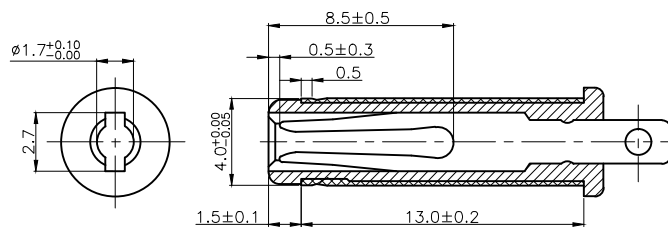
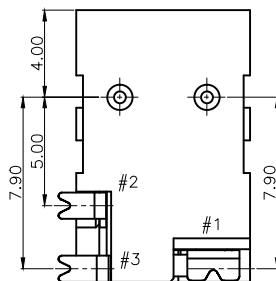
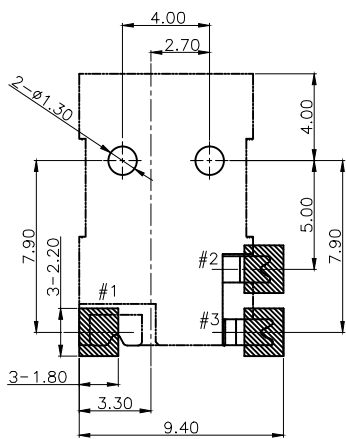
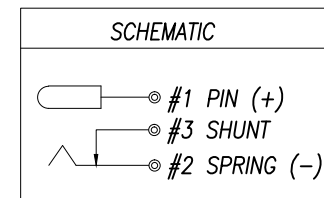
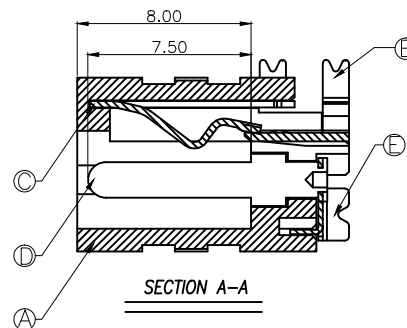
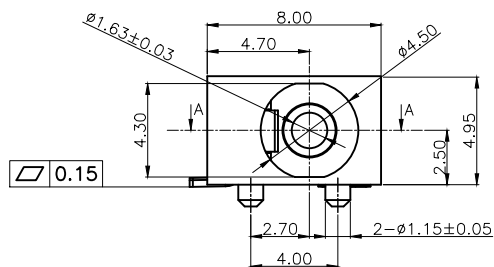
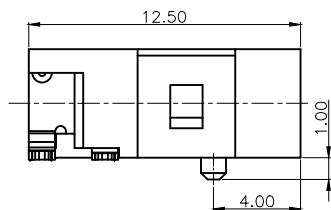

RECOMMENDED PADS LAYOUT
NOTE:TOLERANCE FOR PCB LAYOUT IS ±0.05
<TOP VIEW>

NO	DESCRIPTION	QTY	MATERIAL	PLATING & COLOR
E	TERMINAL	1	BRASS T=0.20	Matte Sn120u"Min On Over Ni20u"Min.
D	CENTER PIN	1	BRASS	
C	SPRING	1	COPPY ALLOY T=0.30	Ag60u"Min On Over Ni20u"Min.
B	SHUNT	1	COPPY ALLOY T=0.40	
A	HOUSING	1	HIGH TEMP THERMOPLASTIC UL 94V-0	BLACK
UNLESS OTHERWISE SPECIFIED TOLERANCES		Singatron Enterprise Co., Ltd. 信音企業股份有限公司		
DECIMALS:		TITLE: DC POWER JACK		
X	:±0.5	X	:±2°	DWN Huanhuan PART NO. 2DC1503-002111F
X.X	:±0.3	X.X	:±1°	CHKD Lussen SCALE:N/A UNIT: mm
X.XX	:±0.2			APVD Liao SIZE: A3 SHEET:1 OF 2 REV:A
CUSTOMER COPY				

REV.	ECN NO OR DESCRIPTION	REVISED	DATE
A	PDR NO. T220222-3A	Huanhuan	2023.02.08

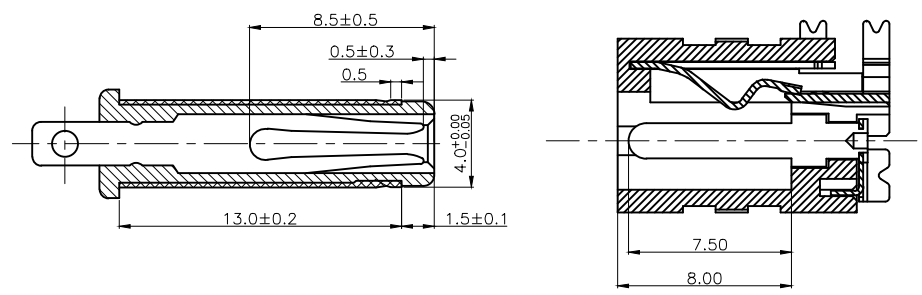

1. 正極接觸狀態

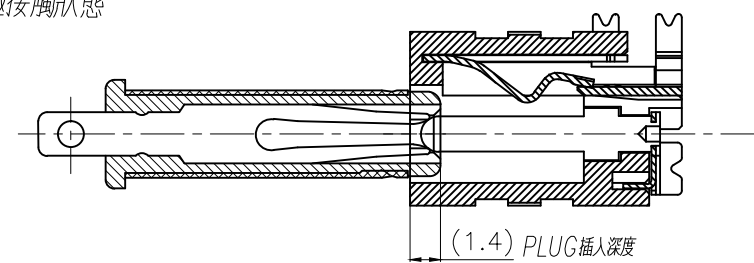

2. 負極接觸狀態

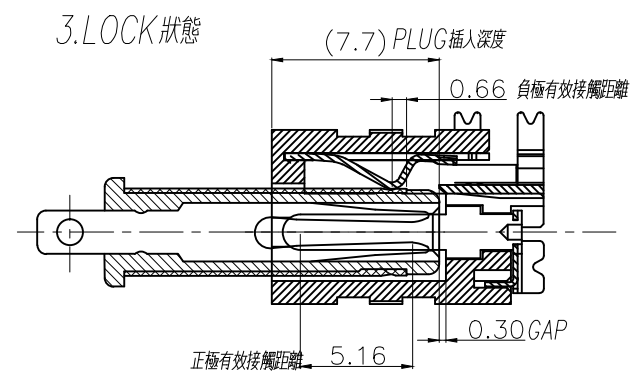
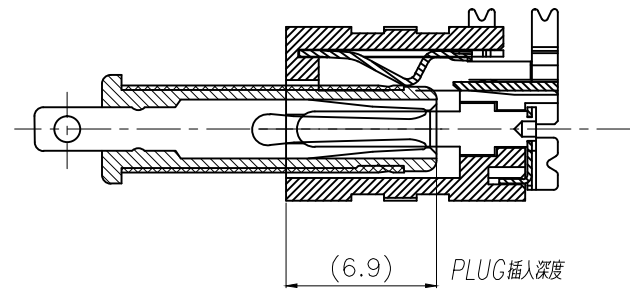

3. LOCK狀態

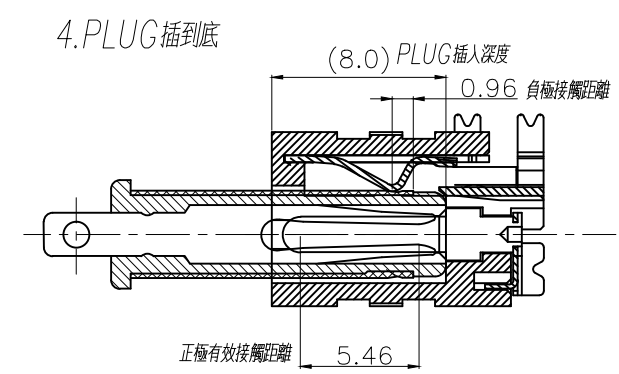

4. PLUG插到底

NO	DESCRIPTION	QTY	MATERIAL	PLATING & COLOR
UNLESS OTHERWISE SPECIFIED TOLERANCES			Singatron Enterprise Co., Ltd. 信音企業股份有限公司	
DECIMALS:	ANGLES:	TITLE	DC POWER JACK MATING DRAWING	
X :±0.5	X :±2°	DWN Huanhuan	PART NO. 2DC1503-002111F	
X.X :±0.3	X.X :±1°	CHKD Lussen	SCALE:N/A	UNIT: mm
X.XX :±0.2		APVD Liao	SIZE: A3	SHEET:2 OF 2
REV:A				
CUSTOMER COPY				