

REV.	ECN NO OR DESCRIPTION	REVISED	DATE
A	PDR RELEASE	IVY-C	2012.08.30
B	ECN NO:L120166	IVY-C	2012.12.04
C	ECN NO:L130031	Even	2013.05.17
D	ECN NO:L140078	IVY-C	2014.07.15

**SPECIFICATIONS:**

1. RATING: DC 12V, 7A.
2. CONTACT RESISTANCE: 30 mΩ MAX.
3. INSULATION RESISTANCE: 100M Ohms MIN. @ 500V DC
4. WITHSTANDING VOLTAGE: 500V AC 1 MINUTE.
5. INSERTION FORCE: 0.3Kgf TO 3.0 Kgf
6. EXTRACTION FORCE: 0.3Kgf TO 3.0 Kgf
7. LIFE TEST: 5000 CYCLES.
8. TO CONFORM TO THE SINGATRON HAZARDOUS SUBSTANCE FREE SPEC.
9. GREEN PRODUCT IDENTIFICATION LABEL ON PACKAGING: **G.P. PASS**
10. OTHER GENERAL SPEC. TO REFER "DC POWER JACK SPEC"
11. PACKAGE: SEE "2DC1524 SERIES" PACKAGE.
12. FOR WAVE SOLDERING LEAD-FREE PROCESS.

**PART NO.**

**2DC1524-000111H**

- SUFFIX: HALOGEN
- PACKAGE  
1: BAG
- HOUSING COLOR  
1: BLACK
- CONTACT PLATING  
1: CENTER PIN Ag PLATED,  
TERMINAL Ag PLATED.

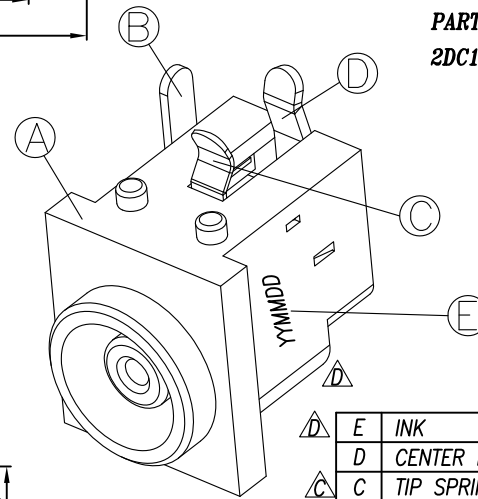

NO	DESCRIPTION	QTY	MATERIAL	PLATING & COLOR
E	INK			BLACK
D	CENTER PIN	1	COPPER ALLOY	Ag PLATING
C	TIP SPRING	1	STAINLESS STEEL	Ag PLATING
B	SHUNT TERMINL	1	COPPER ALLOY	Ag PLATING
A	HOUSING	1	THERMOPLASTIC UL94-V0	BLACK

UNLESS OTHERWISE SPECIFIED TOLERANCES

Singatron Enterprise Co., Ltd.  
信音企業股份有限公司

DECIMALS: X :±0.5  
X.X :±0.3  
X.XX :±0.2

ANGLES: X :±2°  
X.X :±1°

TITLE	DC POWER JACK, R/A, DIP TYPE		
DWN	MY-C 2014.07.15	<b>PART NO. 2DC1524-000111H</b>	
CHKD	SCALE 4:1	UNIT: mm	REV: D
APVD	SIZE: A3	SHEET: 1 OF 1	REV: D

**CUSTOMER COPY**

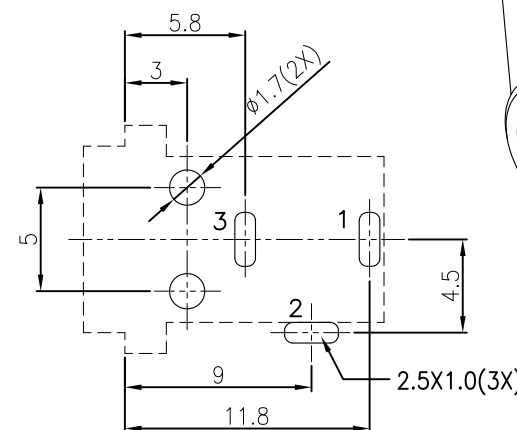
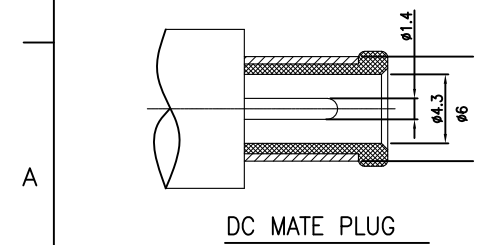
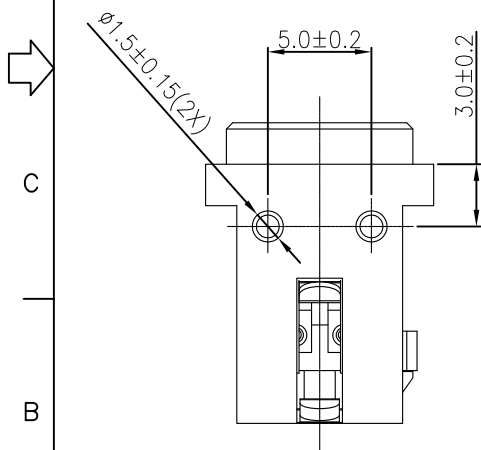
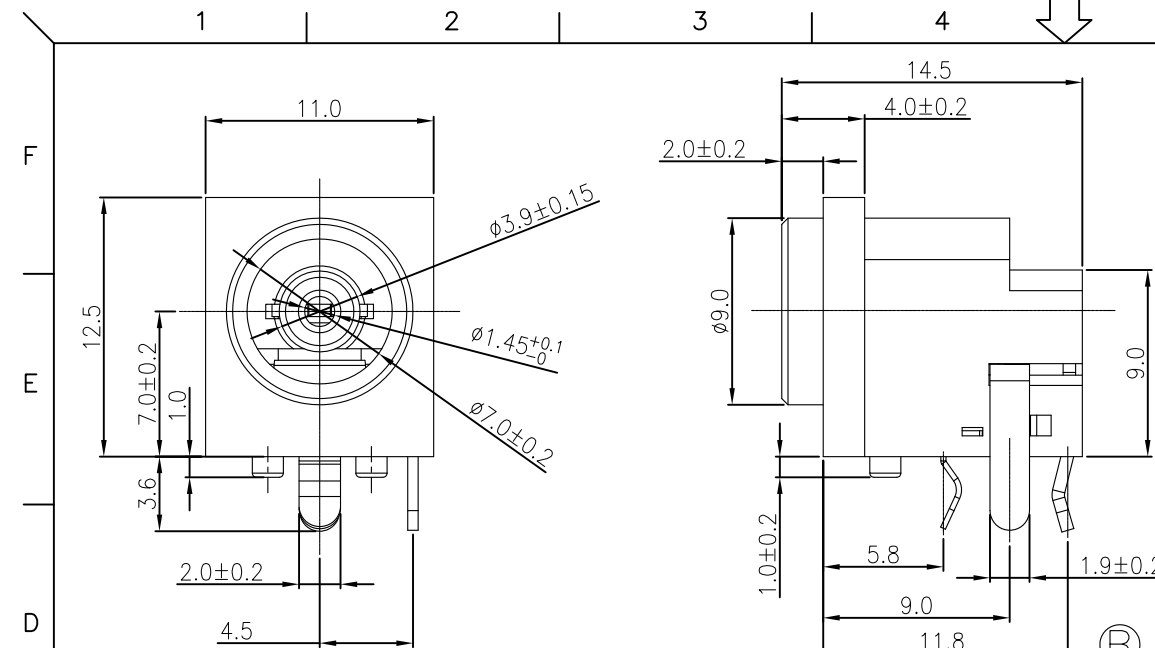
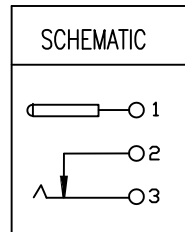

T:1.6 Dimensions of PC board holes  
Tolerance : ±0.1(Printed-top view)