

REV/ECN NO OR DESCRIPTION	REVISED	DATE
A PDR RELEASE	EVEN	2019.03.27

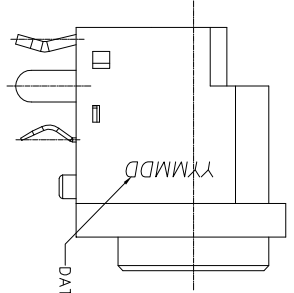
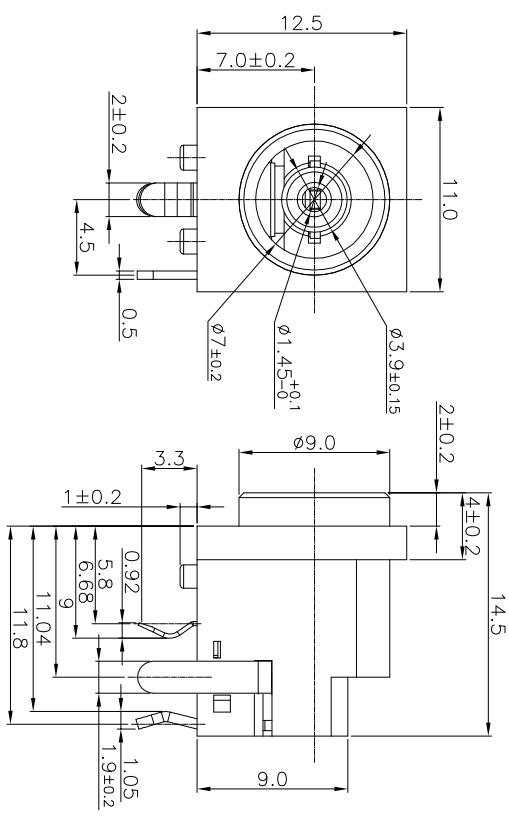

- SPECIFICATIONS:
1. RATING: DC 54V, 35A.
  2. CONTACT RESISTANCE: 50 mΩ MAX.
  3. INSULATION RESISTANCE: 100M Ohms MIN. @ 500V DC
  4. WITHSTANDING VOLTAGE: 500V AC 1 MINUTE.
  5. INSERTION FORCE: 0.3Kgf TO 3.0 Kgf
  6. EXTRACTION FORCE: 0.3Kgf TO 3.0 Kgf
  7. LIFE TEST: 5000 CYCLES.
  8. TO CONFORM TO THE SINGATRON HAZARDOUS SUBSTANCE FREE SPEC.
  9. GREEN PRODUCT IDENTIFICATION LABEL ON PACKAGING: **G.P. PASS**
  10. OTHER GENERAL SPEC. TO REFER "2DC1524-003111H" PACKAGE.
  11. PACKAGE: SEE "2DC1524-003111H" PACKAGE.
  12. FOR WAVE SOLDERING LEAD-FREE PROCESS.

**PART NO.**

**2DC1524-003111H**

- SUFFIX: HALOGEN
- PACKAGE
- 1: BAG
- HOUSING COLOR
- 1: BLACK
- CONTACT PLATING
- 1: Ag PLATED

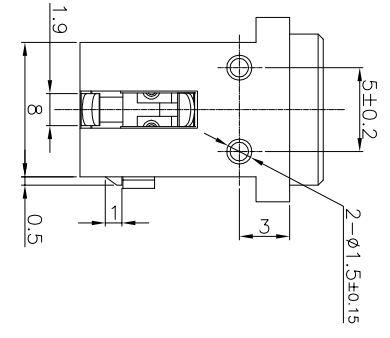

RECOMMENDED P. C. B. LAYOUT  
UNSPECIFIED TOLERANCE: ±0.05  
(TOP VIEW)

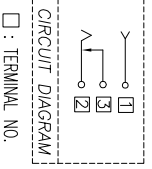
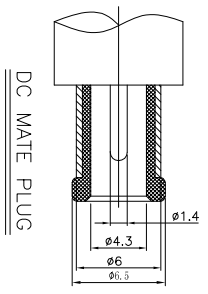
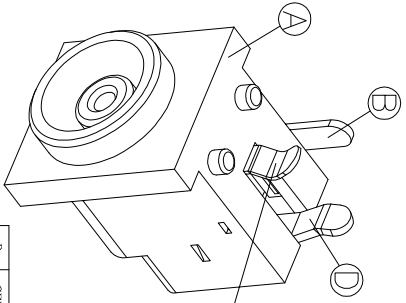
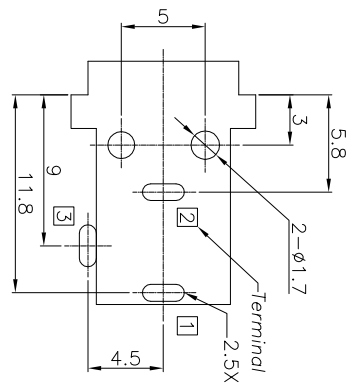

D	CENTER PIN	1	C5191R-II	Ag 8u" MIN., Ni: 40u" Min
C	TTP SPRING	1	SUS 301	Ag 8u" MIN., Ni: 40u" Min
B	SHUNT TERMINAL	1	C2680R-II	Ag 8u" MIN., Ni: 40u" Min
A	HOUSING	1	P166 UL 94V-0	BLACK
NO	DESCRIPTION	QTY	MATERIAL	PLATING & COLOR
UNLESS OTHERWISE SPECIFIED TOLERANCES				
Singatron Enterprise Co., Ltd. 信音企業股份有限公司				
TITLE: DC POWER JACK, R/A, DIP TYPE				
DIMEN		PART NO. <b>2DC1524-003111H</b>		
CHRD		SCALE 4:1	UNTT: mm	
APVD		ANGULAR DIM: °	SIZE: A3	SHEET: 1 OF 1
<b>CUSTOMER COPY</b>				
DECIMALS:		ANGLES:		
X	: ±0.5	X	: ±2°	
X.X	: ±0.3	X.X	: ±1°	
X.XX	: ±0.2			