

|                            |         |            |
|----------------------------|---------|------------|
| REV. ECN NO OR DESCRIPTION | REVISED | DATE       |
| A PDR RELEASE              | IVY-C   | 2014.05.19 |

**SPECIFICATIONS:**

1. RATING: DC 20V, 6A.
2. CONTACT RESISTANCE: 30 mΩ MAX.
3. INSULATION RESISTANCE: 100M Ohms MIN.
4. WITHSTANDING VOLTAGE: 500V AC 1 MINUTE.
5. INSERTION FORCE: 0.3Kgf TO 3.0 Kgf
6. EXTRACTION FORCE: 0.3Kgf TO 3.0 Kgf
7. LIFE TEST: 5000 CYCLES.
8. TO CONFORM TO THE SINGATRON HAZARDOUS SUBSTANCE FREE SPEC.
9. GREEN PRODUCT IDENTIFICATION LABEL ON PACKAGING: **[G.P.PASS]**
10. OTHER GENERAL SPEC. TO REFER "2DC1532-001111H SERIES SPEC"
11. PACKAGE: SEE "2DC1532 SERIES" PACKAGE.
12. FOR WAVE SOLDERING LEAD-FREE PROCESS.

**PART NO.**

**2DC1532-001111H**

- SUFFIX: HALOGEN
- PACKAGE 1: PE BAG
- HOUSING COLOR 1: BLACK
- CONTACT PLATING 1: Tin Plating
- TAIL 1: WITH EMBO

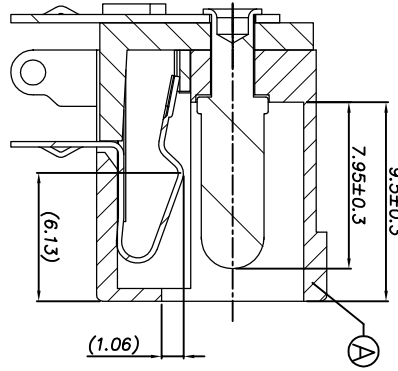
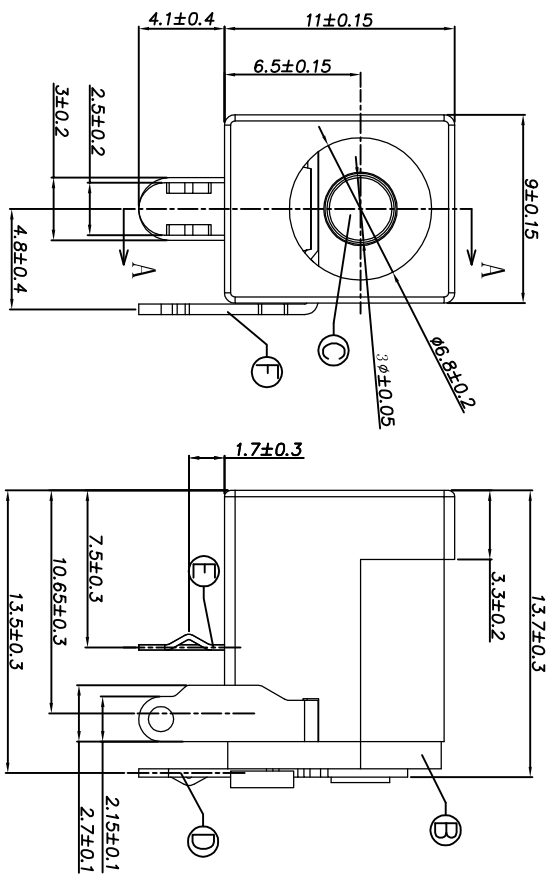
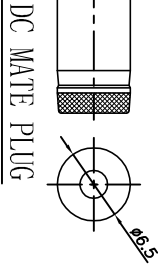

SECTION A-A

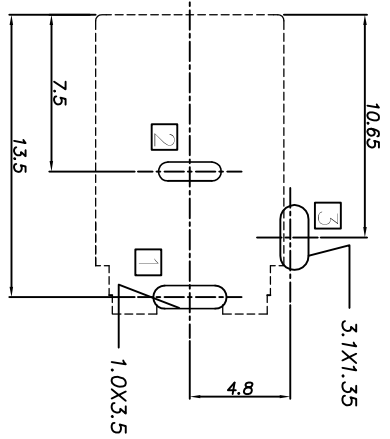

© Date Code

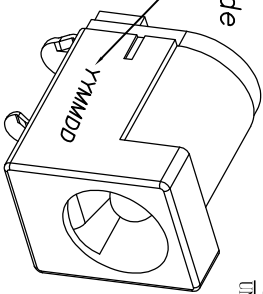

RECOMMENDED P.C.B. LAYOUT  
UNSPECIFIED TOLERANCE: ±0.05  
PCB THICKNESS: 1.40±0.05mm  
(BOTTOM VIEW)

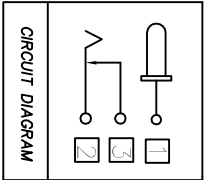

CIRCUIT DIAGRAM

| NO | DESCRIPTION         | QTY | MATERIAL                            | PLATING & COLOR     |
|----|---------------------|-----|-------------------------------------|---------------------|
| A  | HOUSING             | 1   | ENGINEERING THERMO-PLASTIC UL 94V-0 | BLACK               |
| B  | COVER               | 1   | ENGINEERING THERMO-PLASTIC UL 94V-0 | BLACK               |
| C  | CENTER PIN          | 1   | COPPER ALLOY                        | CuSn/NICKEL PLATING |
| D  | CENTER PIN TERMINAL | 1   | COPPER ALLOY 0.4t                   | TIN PLATING         |
| E  | TIP SPRING          | 1   | COPPER ALLOY 0.25t                  | TIN PLATING         |
| F  | SHUNT TERMINAL      | 1   | COPPER ALLOY 0.5t                   | BLACK               |
| G  | INK                 |     |                                     | BLACK               |

Singatron Enterprise Co., Ltd.  
信音企業股份有限公司

TITLE: Ø3.0mm DC POWER JACK, R/A, DIP TYPE

DWN: W-4-2014.05.19 PART NO. 2DC1532-001111H

CHKD: SCALE 4:1 UNIT: mm

APVD: AME12014.05.19 SIZE: A3 SHEET: 1 OF 1 REV: A

CUSTOMER COPY