

REV	ECN NO	OR DESCRIPTION	REVISED	DATE
A		PDR RELEASE	Even	2013.05.30

- SPECIFICATIONS:
1. RATING: DC 20V, 3A.
 2. CONTACT RESISTANCE: 50 mΩ MAX.
 3. INSULATION RESISTANCE: 100 MOhms MIN.
 4. WITHSTANDING VOLTAGE: 500V AC 1 MINUTE.
 5. INSERTION FORCE: 0.3kgf TO 3.0 Kgf
 6. EXTRACTION FORCE: 0.3kgf TO 3.0 Kgf
 7. LIFE TEST: 5000 CYCLES.
 8. TO CONFORM TO THE SINGATRON HAZARDOUS SUBSTANCE FREE SPEC.
 9. GREEN PRODUCT IDENTIFICATION LABEL ON PACKAGING: **G.P. PASS**
 10. OTHER GENERAL SPEC. TO REFER " 2DC1536 SERIES SPEC"
 11. PACKAGE: SEE "2DC1536 SERIES" PACKAGE.
 12. FOR WAVE SOLDERING LEAD-FREE PROCESS.

PART NO.

2DC1536-020111H

- DIM A: SUFFIX: HALOGEN
- 2: 2.0 REF. PACKAGE
- 1: PE BAG
- HOUSING COLOR
- 1: BLACK
- CONTACT PLATING
- 1: Ag PLATING

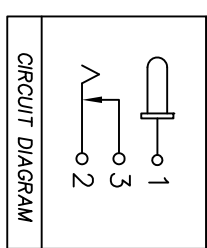
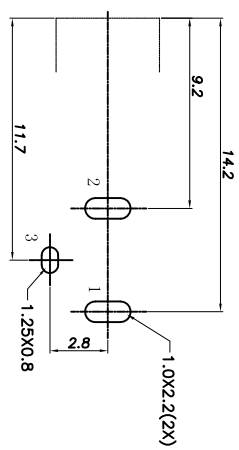
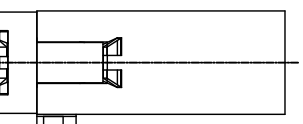
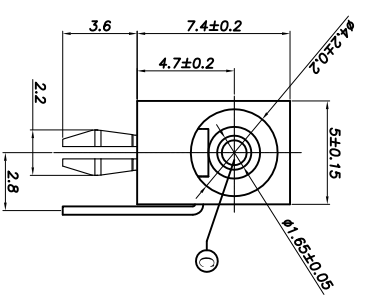
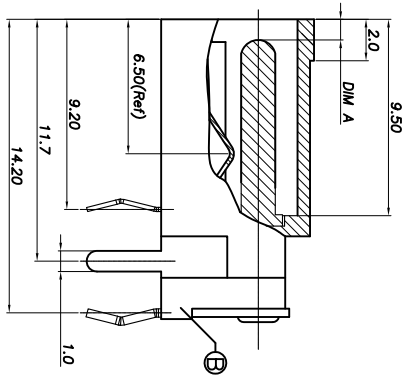
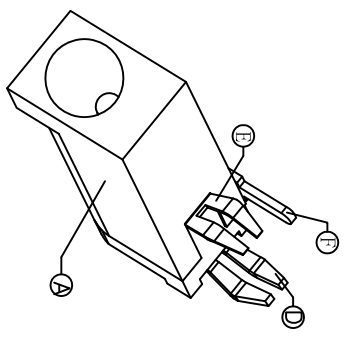

RECOMMENDED P. C. B. LAYOUT
UNSPECIFIED TOLERANCE: ±0.05
(TOP VIEW)

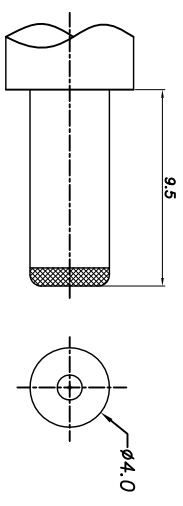

DC MATE PLUG

NO	DESCRIPTION	QTY	MATERIAL	PLATING & COLOR
F	SHUNT TERMINAL	1	COPPER ALLOY	Ag PLATING
E	TIP SPRING	1	STAINLESS STEEL	Ag PLATING
D	CENTER PIN TERMINAL	1	COPPER ALLOY	Ag PLATING
C	CENTER PIN	1	COPPER ALLOY	Ni PLATING
B	COVER	1	ENGINEERING THERMO-PLASTIC UL 94V-0	BLACK
A	HOUSING	1	ENGINEERING THERMO-PLASTIC UL 94V-0	BLACK

UNLESS OTHERWISE SPECIFIED TOLERANCES

DECIMALS: ANGLES:
X :±0.5 X :±2°
X.X :±0.3 X.X :±1°
X.XX :±0.2

Singatron Enterprise Co., Ltd.
信亨企業股份有限公司

TITLE: Ø1.65mm DC POWER JACK, R/A, DIP TYPE
DWV: 2013.05.30 PART NO. 2DC1536-020111H
CHKD: SCALE 4:1 UNIT: mm
APVD: AMBZL 2013.05.30 SIZE: A3 SHEET: 1 OF 1 REV: A

CUSTOMER COPY