

REV.	ECN NO OR DESCRIPTION	REVISED	DATE
A	PDR RELEASE	IVY-C	2015.04.28

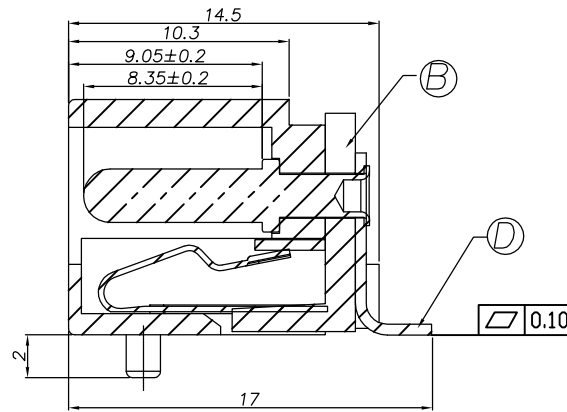

SPECIFICATIONS:

1. RATING: DC 24V, 5A.
2. CONTACT RESISTANCE: 50 mΩ MAX.
3. INSULATION RESISTANCE: 100M Ohms MIN. @500V DC.
4. WITHSTANDING VOLTAGE: 500V AC 1 MINUTE.
5. INSERTION FORCE: 0.3Kgf TO 3.0 Kgf
6. EXTRACTION FORCE: 0.3Kgf TO 3.0 Kgf
7. LIFE TEST: 5000 CYCLES.
8. TO CONFORM TO THE SINGATRON HAZARDOUS SUBSTANCE FREE SPEC.
9. GREEN PRODUCT IDENTIFICATION LABEL ON PACKAGING: **G.P. PASS**
10. PACKAGE: SEE "2DC1547 SERIES" PACKAGE.
11. FOR REFLOW SOLDERING LEAD-FREE PROCESS.
12. OTHER GENERAL SPEC. TO REFER "2DC1547 SERIES SPEC"

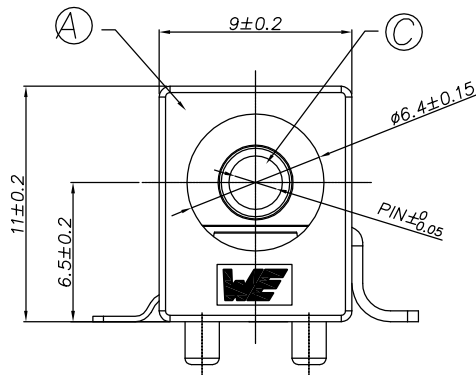
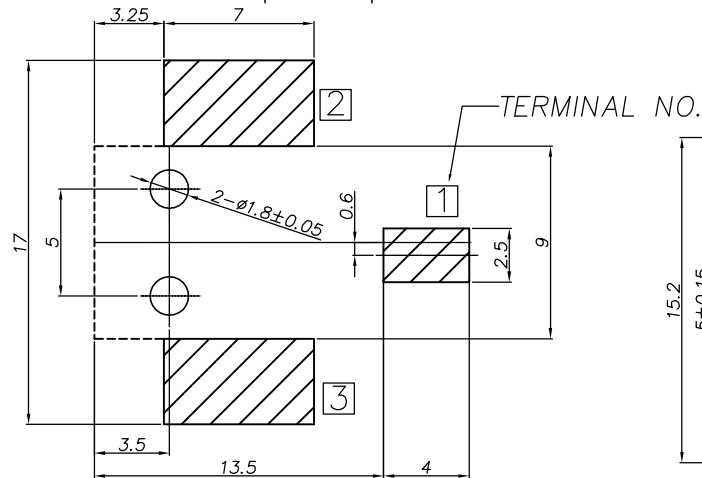

RECOMMENDED P. C. B. LAYOUT
UNSPECIFIED TOLERANCE: ±0.05
(COPPER-TOP VIEW)

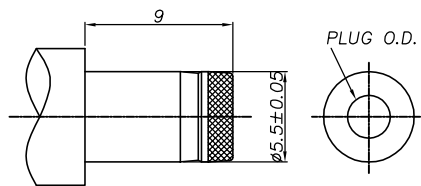

DC MATE PLUG

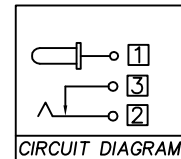
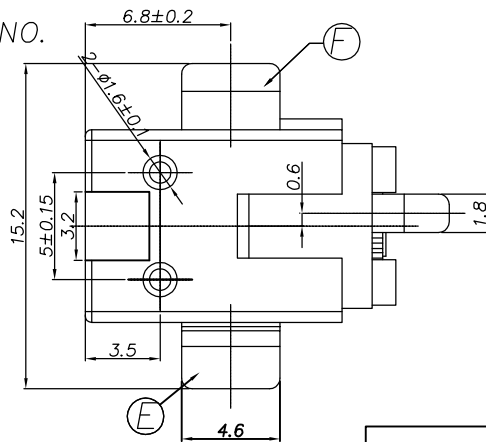

CIRCUIT DIAGRAM

□ : TERMINAL NO.

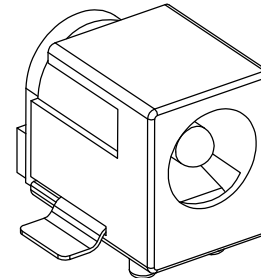

PART NO.
2DC1547-X00111H

- PIN :**
- 1: 2.0ø
 - 2: 2.5ø

- SUFFIX: HALOGEN
- PACKAGE: 1: TAPE & REEL
- HOUSING COLOR: 1: BLACK
- CONTACT PLATING: 1: MATTE TIN PLATING

F	SHUNT TERMINAL	1	BRASS 0.5t	MATTE TIN PLATING
E	TIP SPRING	1	PHOSPHOR BRONZE 0.25t	MATTE TIN PLATING
D	CENTER PIN TERMINAL	1	BRASS 0.5t	MATTE TIN PLATING
C	CENTER PIN	1	BRASS	GOLD FLASH
B	COVER	1	PA-9T UL 94V-0	BLACK
A	HOUSING	1	PA-9T UL 94V-0	BLACK

NO	DESCRIPTION	QTY	MATERIAL	PLATING & COLOR
UNLESS OTHERWISE SPECIFIED TOLERANCES			Singatron Enterprise Co., Ltd. 信音企業股份有限公司	
DECIMALS:		TITLE: DC POWER JACK, SMT TYPE		
X	:±0.5	X	:±2°	DWN <i>IV-C 2015.04.28</i> PART NO. 2DC1547-X00111H
X.X	:±0.3	X.X	:±1°	CHKD <i>ANGELA 2015.04.28</i> SCALE 1:1 UNIT: mm
X.XX	:±0.2	APVD <i>ANGELA 2015.04.28</i> SIZE: A3 SHEET: 1 OF 1 REV: A		

CUSTOMER COPY

PIN	ø2.0	ø2.5
PLUG O.D.	2.05 ^{+0.10} / _{-0.00}	2.55 ^{+0.10} / _{-0.00}