

REV.	ECN NO OR DESCRIPTION	REVISED	DATE
A	PDR RELEASE	IVY-C	2015.09.21
B	ECN NO: L160006	IVY-C	2016.01.26

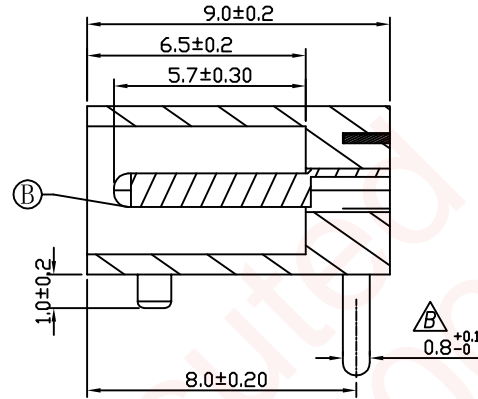

SPECIFICATIONS:

1. RATING: DC 20V, 2A.
2. CONTACT RESISTANCE: ≤50m Ohms
3. INSULATION RESISTANCE: 100M Ohms MIN. @500V DC.
4. WITHSTANDING VOLTAGE: 500V AC 1 MINUTE.
5. INSERTION FORCE: 0.3Kgf TO 3.0 Kgf
6. EXTRACTION FORCE: 0.3Kgf TO 3.0 Kgf
7. LIFE TEST: 5000 CYCLES.
8. TO CONFORM TO THE SINGATRON HAZARDOUS SUBSTANCE FREE SPEC.
9. GREEN PRODUCT IDENTIFICATION LABEL ON PACKAGING: **G.P. PASS**
10. PACKAGE: SEE "2DC1550 SERIES" PACKAGE.
11. FOR WAVE SOLDERING LEAD-FREE PROCESS.
12. OTHER GENERAL SPEC. TO REFER "2DC1550 SERIES SPEC"

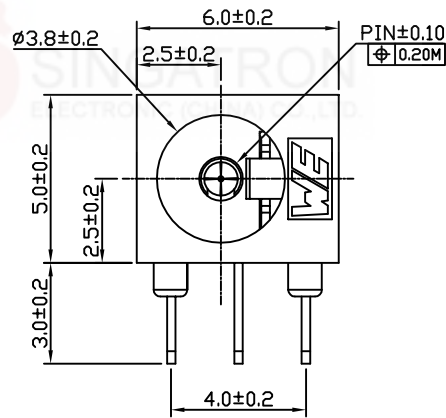
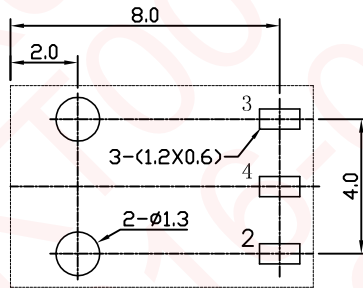
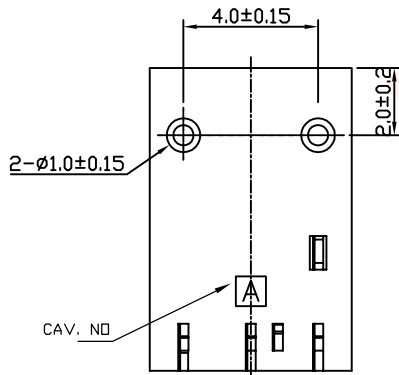

**P.C.B LAYOUT
TOP VIEW**

PART NO.

2DC1550-X01111H

PIN :
1: 1.0Ø
2: 1.3Ø

- SUFFIX: HALOGEN
- PACKAGE: 1: TRAY
- HOUSING COLOR: 1: BLACK
- CONTACT PLATING: 1: TIN PLATING
- HOUSING MATERIAL: 1: LCP

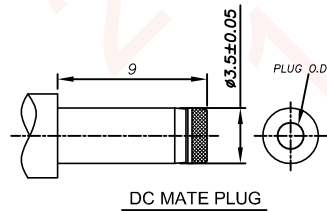
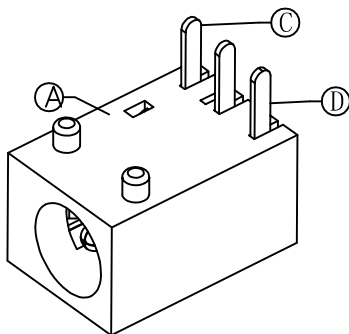

PIN	Ø1.0	Ø1.3
PLUG O.D.	1.05 ^{+0.03} / _{-0.02}	1.35 ^{+0.03} / _{-0.02}

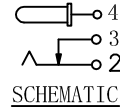

D	SHUNT TERMINAL	1	BRASS 0.25t	TIN PLATING
C	TIP SPRING	1	PHOSPHOR BRONE 0.25t	TIN PLATING
B	CENTER PIN	1	BRASS 0.25t	GOLD FLASH
A	HOUSING	1	SEE "PART NO."	BLACK
NO	DESCRIPTION	QTY	MATERIAL	PLATING & COLOR

UNLESS OTHERWISE SPECIFIED TOLERANCES

Singatron Enterprise Co., Ltd.
信音企業股份有限公司

DECIMALS:	ANGLES:	TITLE	DC POWER JACK, DIP TYPE	
X : ±0.5	X : ±2°	DWN	NY-C 2016.01.26	PART NO. 2DC1550-X01111H
XX : ±0.3	XX : ±1°	CHKD	ANGELA/2016.01.26	SCALE 1:1 UNIT: mm
XX.XX : ±0.2		APVD	ANGELA/2016.01.26	SIZE: A3 SHEET: 1 OF 1 REV: B

CUSTOMER COPY