

REV.	ECN NO OR DESCRIPTION	REVISED	DATE
A	PDR RELEASE	Even	2017.11.29

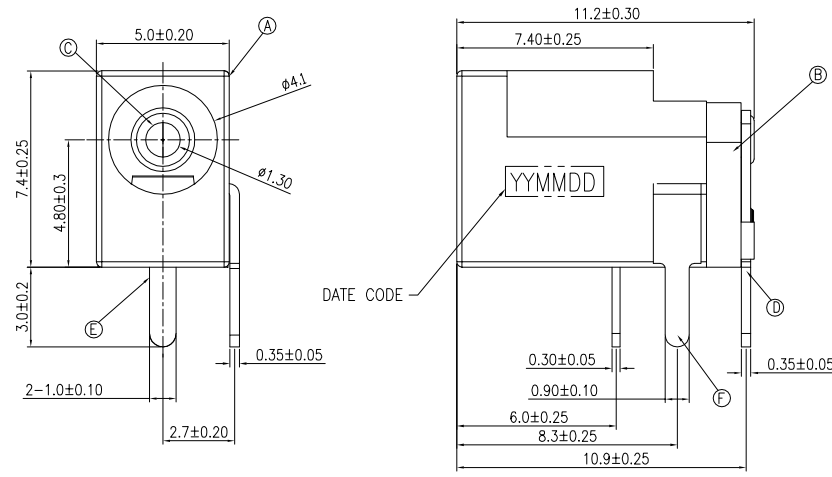

- SPECIFICATIONS:**
1. RATING: DC 30V, 2A.
 2. CONTACT RESISTANCE: 50 mΩ MAX.
 3. INSULATION RESISTANCE: 100M Ohms MIN. @500V DC.
 4. WITHSTANDING VOLTAGE: 500V AC 1 MINUTE.
 5. INSERTION FORCE: 0.3Kgf TO 3.0 Kgf
 6. EXTRACTION FORCE: 0.3Kgf TO 3.0 Kgf
 7. LIFE TEST: 5000 CYCLES.
 8. TO CONFORM TO THE SINGATRON HAZARDOUS SUBSTANCE FREE SPEC.
 9. HALOGEN FREE PRODUCT IDENTIFICATION LABEL ON PACKAGING:
 10. PACKAGE: SEE "2DC1551-302212F" PACKAGE.
 11. FOR REFLOW SOLDERING LEAD-FREE PROCESS.
 12. OTHER GENERAL SPEC. TO REFER "2DC1551-302212F SPEC"

PART NO.

2DC1551-302212F

- PIN : ——— SUFFIX: HALOGEN FREE
 3: 1.3Ø ——— PACKAGE
 ——— 2: TAPE & REEL
 ——— HOUSING COLOR
 ——— 1: BLACK
 ——— CONTACT PLATING
 ——— 2: Ag PLATING

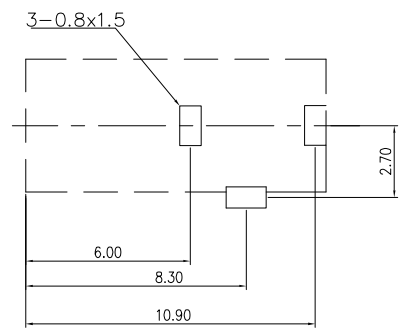

RECOMMENDED PCB LAYOUT
TOP VIEW (TOLERANCE:±0.05)

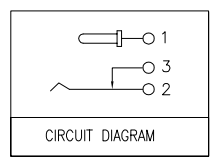

F	SHUNT TERMINAL	1	H65	Ag PLATING
E	TIP SPRING	1	C5191	Ag PLATING
D	CENTER PIN TERMINAL	1	H65	Ag PLATING
C	CENTER PIN	1	H65	Sn PLATING
B	COVER	1	PA10T UL 94V-0	BLACK
A	HOUSING	1	PA10T UL 94V-0	BLACK

NO	DESCRIPTION	QTY	MATERIAL	PLATING & COLOR
UNLESS OTHERWISE SPECIFIED TOLERANCES				
			Singatron Enterprise Co., Ltd.	
			信音企業股份有限公司	
DECIMALS:		ANGLES:	TITLE: DC POWER JACK, DIP TYPE	
X	:±0.5	X	:±2°	DWN
X.X	:±0.3	X.X	:±1°	CHKD
X.XX	:±0.2			APVD
EVEN 2017.11.29		PART NO. 2DC1551-302212F		UNIT: mm
ANGELA2017.11.29		SCALE 1:1		⊕
ANGELA2017.11.29		SIZE: A3		SHEET: 1 OF 1
				REV:A
CUSTOMER COPY				