

REV.	ECN NO OR DESCRIPTION	REVISED	DATE
A	PDR RELEASE	IVY-C	2014.12.02

SPECIFICATIONS:

1. RATING: DC 30V, 2A.
2. CONTACT RESISTANCE: 50 mΩ MAX.
3. INSULATION RESISTANCE: 100M Ohms MIN. @500V DC.
4. WITHSTANDING VOLTAGE: 500V AC 1 MINUTE.
5. INSERTION FORCE: 0.3Kgf TO 3.0 Kgf
6. EXTRACTION FORCE: 0.3Kgf TO 3.0 Kgf
7. LIFE TEST: 5000 CYCLES.
8. TO CONFORM TO THE SINGATRON HAZARDOUS SUBSTANCE FREE SPEC.
9. GREEN PRODUCT IDENTIFICATION LABEL ON PACKAGING: **G.P. PASS**
10. PACKAGE: SEE "2DC1551 SERIES" PACKAGE.
11. FOR WAVE SOLDERING LEAD-FREE PROCESS.
12. OTHER GENERAL SPEC. TO REFER "2DC1551 SERIES SPEC"

PART NO.

2DC1551-X01111H

- PIN :
- 2: 1.0φ
 - 3: 1.3φ
- SUFFIX: HALOGEN
 - PACKAGE
 - 1: BAG
 - HOUSING COLOR
 - 1: BLACK
 - CONTACT PLATING
 - 1: TIN PLATING
 - HOUSING MATERIAL
 - 1: PA66 A63V0

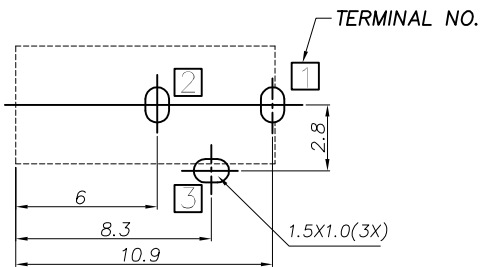
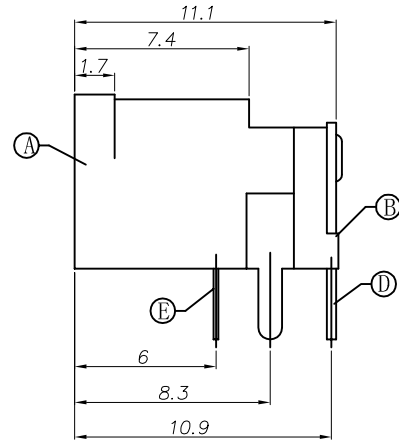
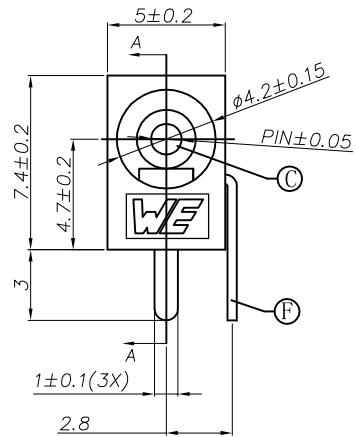

RECOMMENDED P. C. B. LAYOUT
UNSPECIFIED TOLERANCE: ±0.05
(TOP VIEW)

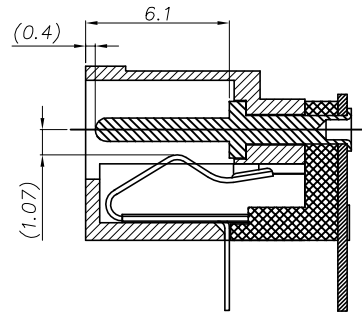

SECTION A-A

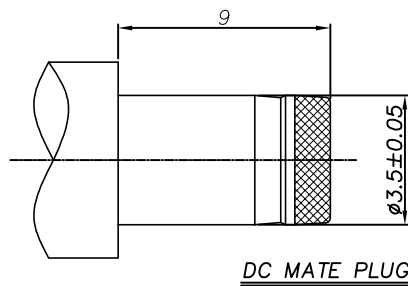

DC MATE PLUG

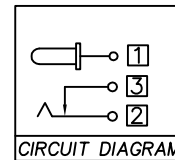

CIRCUIT DIAGRAM

□ : TERMINAL NO.

PIN	φ1.0	φ1.3
DC PLUG O.D.	1.05 ^{+0.10} / _{-0.06}	1.35 ^{+0.10} / _{-0.06}

F	SHUNT TERMINAL	1	BRASS 0.4t	TIN PLATING
E	TIP SPRING	1	STAINLESS STEEL 0.2t	TIN PLATING
D	CENTER PIN TERMINAL	1	BRASS 0.4t	TIN PLATING
C	CENTER PIN	1	BRASS	GOLD FLASH
B	COVER	1	PA66 A63V0	BLACK
A	HOUSING	1	PA66 A63V0	BLACK

NO	DESCRIPTION	QTY	MATERIAL	PLATING & COLOR
UNLESS OTHERWISE SPECIFIED TOLERANCES		Singatron Enterprise Co., Ltd. 信音企業股份有限公司		
DECIMALS:	ANGLES:	TITLE	DC POWER JACK, DIP TYPE	
X : ±0.5	X : ±2°	DWN	NY-C 2014.12.02	PART NO. 2DC1551-X01111H
X.X : ±0.3	X.X : ±1°	CHKD	SCALE 1:1	UNIT: mm
X.XX : ±0.2		APVD	ANGELA2014.12.02	SIZE: A3 SHEET: 1 OF 1 REV: A
CUSTOMER COPY				