

| REV. | ECN NO OR DESCRIPTION | REVISED | DATE |
|------|-----------------------|---------|------------|
| A | PDR RELEASE | Even | 2015.01.06 |

- SPECIFICATIONS:
1. RATING: DC 12V, 2A.
 2. CONTACT RESISTANCE: 50 mΩ MAX.
 3. INSULATION RESISTANCE: 100M Ohms MIN. @500V DC.
 4. WITHSTANDING VOLTAGE: 500V AC 1 MINUTE.
 5. INSERTION FORCE: 0.3Kgf TO 3.0 Kgf
 6. EXTRACTION FORCE: 0.3Kgf TO 3.0 Kgf
 7. LIFE TEST: 5000 CYCLES.
 8. TO CONFORM TO THE SINGATRON HAZARDOUS SUBSTANCE FREE SPEC.
 9. GREEN PRODUCT IDENTIFICATION LABEL ON PACKAGING: **G.P. PASS**
 10. PACKAGE: SEE "2DC1555 SERIES" PACKAGE.
 11. FOR WAVE SOLDERING LEAD-FREE PROCESS.
 12. OTHER GENERAL SPEC. TO REFER "2DC1555 SERIES SPEC"

PART NO.

2DC1555-001111H

- SUFFIX: HALOGEN
- PACKAGE
- 1: BAG
- HOUSING COLOR
- 1: BLACK
- CONTACT PLATING
- 1: TIN PLATING
- HOUSING MATERIAL
- 1: PA66 A63V0

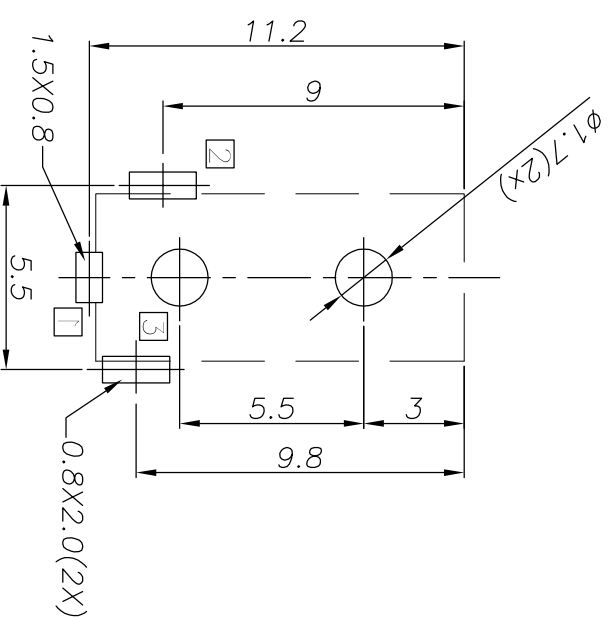
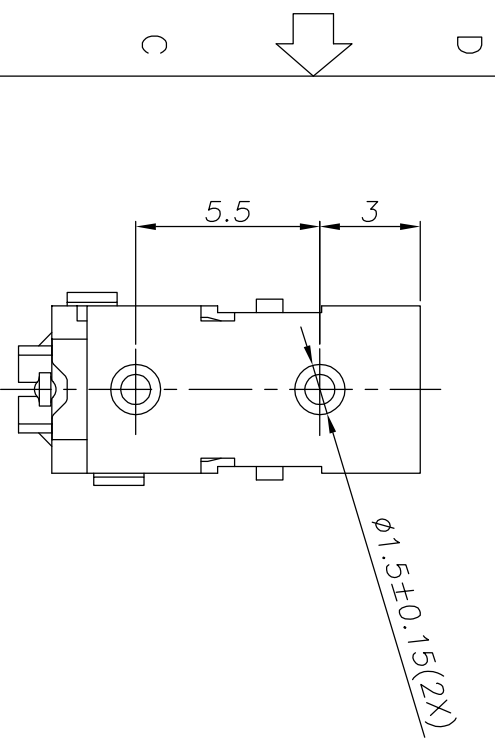
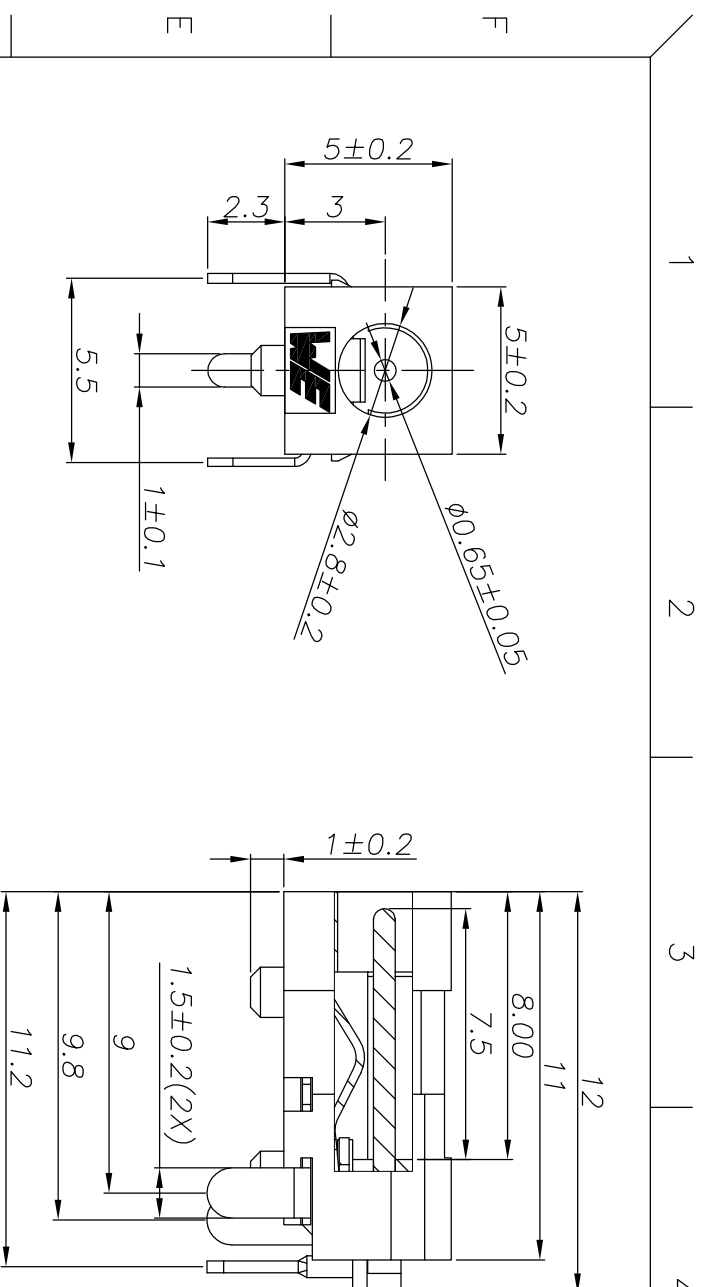

RECOMMENDED P. C. B. LAYOUT
UNSPECIFIED TOLERANCE: ±0.05
(TOP VIEW)

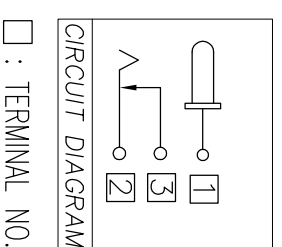
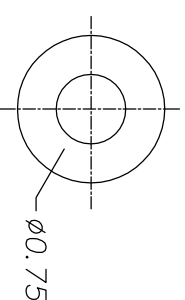
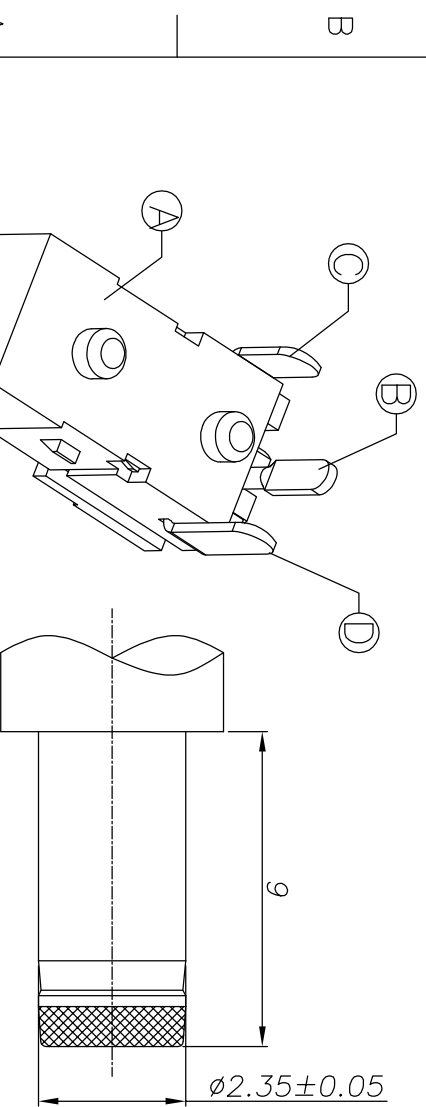

DC MATE PLUG

| NO | DESCRIPTION | QTY | MATERIAL | PLATING & COLOR |
|----|----------------|-----|--------------------|-----------------|
| D | SHUNT TERMINAL | 1 | BRASS 0.3t | TIN PLATING |
| C | TIP SPRING | 1 | COPPER ALLOY 0.25t | TIN PLATING |
| B | CENTER PIN | 1 | PHOSPHOR BRONZE | GOLD FLASH |
| A | HOUSING | 1 | PA66 A63V0 | BLACK |

| | |
|-------------|-----------|
| DECIMALS: | ANGLES: |
| X : ±0.5 | X : ±2° |
| X.X : ±0.3 | X.X : ±1° |
| X.XX : ±0.2 | |

| | |
|-------|-------------------------|
| TITLE | DC POWER JACK, DIP TYPE |
| DWN | Even 2015.01.06 |
| CHKD | |
| APVD | ANGEL2015.01.07 |

Singatron Enterprise Co., Ltd.
信音企業股份有限公司

PART NO. 2DC1555-001111H

CUSTOMER COPY